

Stainless & Hard

BALITHERM IONIT ST treatment for austenitic steels for food processing industries



General Engineering



BALITHERM IONIT ST – an alternative to carburising for stainless steel

Corrosion-resistant surface hardening of austenitic stainless steel

- Nitrogen diffusion process with no formation of chromium nitride precipitation
- Hardness: 1,000 - 1,200 HV0.1
- Diffusion depths: 5 – 30 µm, depending on the material and treatment time
- High wear resistance
- High corrosion resistance
- Practically no dimensional change
- Typical steels: 1.4301; 1.4401; 1.4404

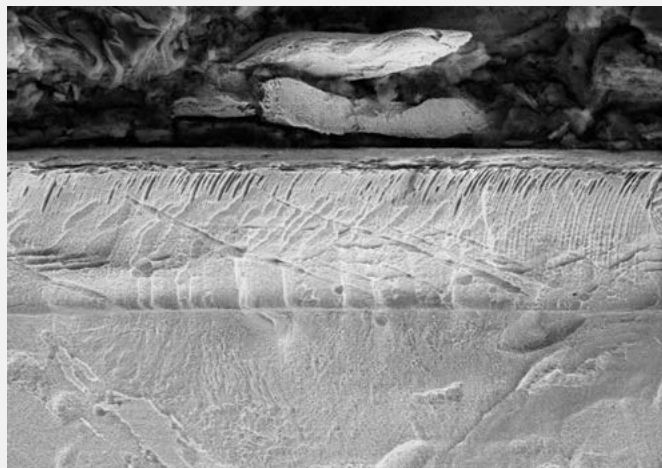

SEM photo of cross section of BALITHERM IONIT ST, showing a standard 20 µm thick diffusion zone on a DIN 1.4301 steel

Hardness profile surface treated with Balitherm® Ionit ST versus a standard carburised surface

Material: steel 1.4301

BALITHERM® IONIT ST achieves 1,200 HV
while carburising achieves just 1,000 HV

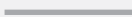
BALITHERM® IONIT ST 
Carburised 

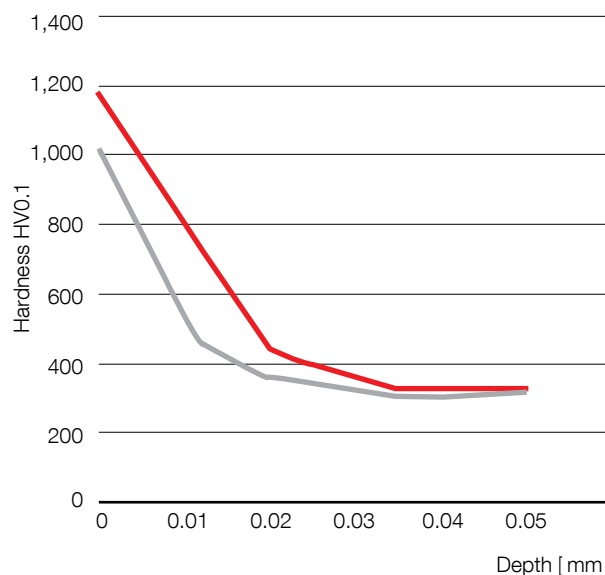

BALITHERM® IONIT ST is a low-temperature diffusion process

It achieves a dense diffusion zone with no nitride precipitation, ensuring retention of corrosion resistance, high hardness and a graduated hardness profile.



BALITHERM IONIT ST – a reliable diffusion process for austenitic stainless steels

Food processing and other industries use austenitic stainless steel for mechanical components. This type of steel provides excellent corrosion resistance, but has the significant disadvantage of low hardness (approx. 250 HV). Consequently, they offer low wear resistance, both against particles (abrasion) and when sliding against another stainless steel component (adhesive wear, galling).

Frequently, hard chrome plating is used to improve the wear resistance. Hard chrome plating is prone to flaking off under severe load conditions or due to coating process failures.

Diffusion treatment can be considered as an alternative. Unfortunately, it is very difficult to nitride austenitic stainless steel, especially at the low temperatures, which are required in order to prevent a reduction of the steel's corrosion resistance. One solution already on the market is a carburising process.

Oerlikon Balzers is now introducing a powerful alternative: the BALITHERM® IONIT ST process, in which nitrogen at low temperatures is diffused into austenitic steel.

Your advantages using austenitic steel parts treated with BALITHERM IONIT ST



Significantly higher hardness and therefore wear resistance compared to untreated steel

No danger of flaking compared to hard chromium

Almost no loss of corrosion resistance

Superior hardness, wear resistance and corrosion resistance compared to carburising

BALITHERM IONIT ST – friction and wear

High sliding wear resistance

Measurement conditions

Method	pin (1) and disc (2)
Load	10 N
Distance	1,000 m
Speed	30 cm/s
Temperature	20 °C
Humidity	43%
Counterface	steel ball, 100Cr6, 3 mm

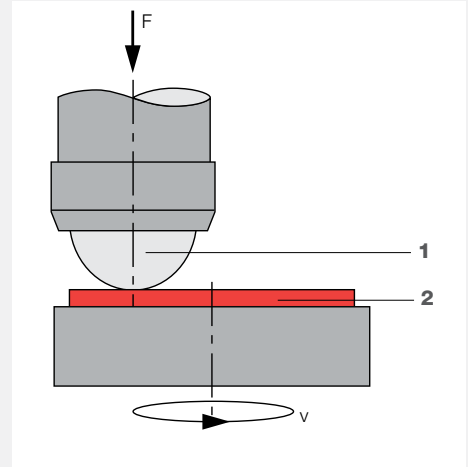

Result

BALITHERM® IONIT ST delivers significantly higher sliding wear resistance than the carburising process

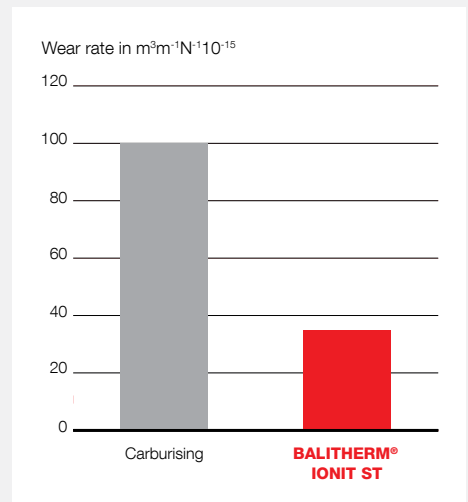
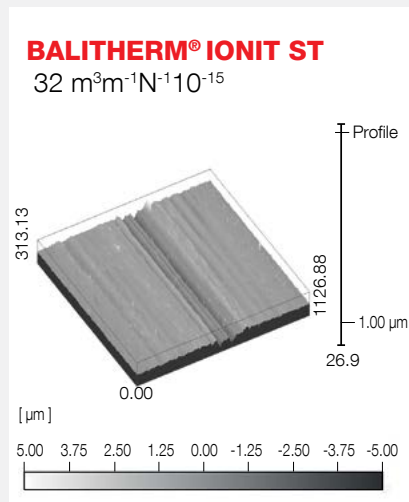
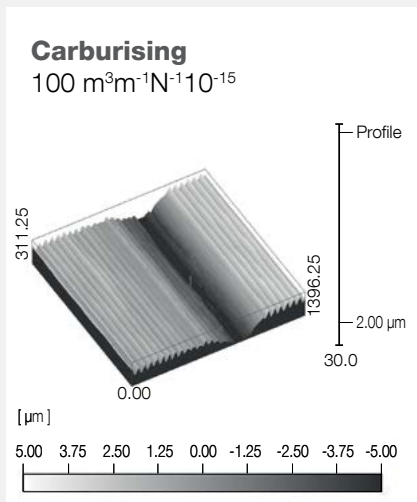

Excellent corrosion resistance

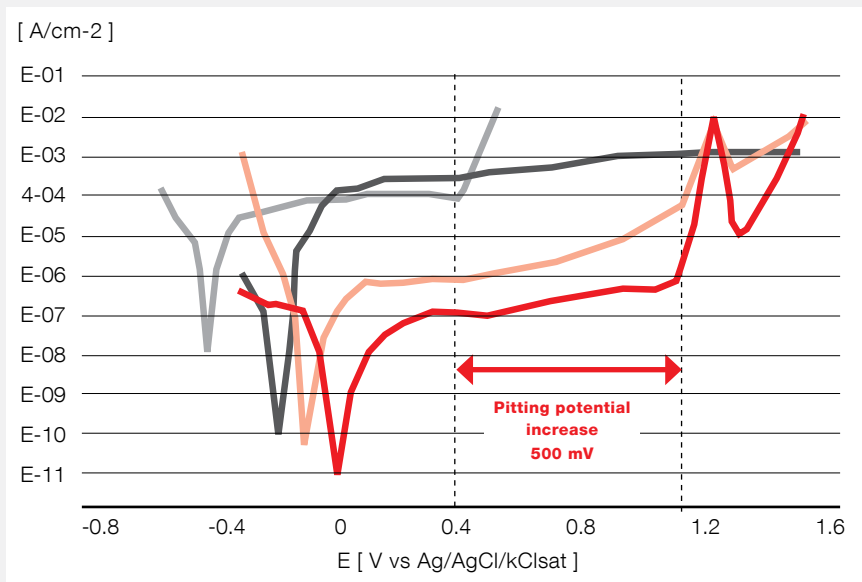

- Reference (1.4301)
- IONIT ST long
- IONIT ST short
- Carburising

The measuring shows an improvement of the pitting behavior in comparison to an untreated 1.4301 sample.

BALITHERM IONIT ST – application examples

Powerful in food processing

BALITHERM® IONIT ST is used in bottling and filling applications where either metal sliding wear or media particle wear must be prevented.



Seizure of a 1.4301 marmelade filling plunger which **could be prevented with BALITHERM® IONIT ST treatment.**

Other applications: candy and medical tablet punches.

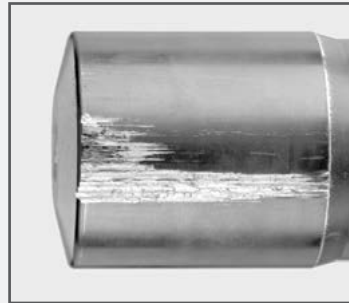

BALITHERM IONIT ST – analytical results

Food acceptance analysis

BALITHERM® IONIT ST is qualified for direct contact with food.

Within the scope of the analysed parameters, it has been ascertained that the material qualifies for prolonged direct contact with food. The results indicate that the material remains unaltered after exposure to the representative solutions.

Certified by Institut Prof. Kurz GmbH, Cologne, 2015

Chemical results

Representative solution	Reaction
Aqua dem.	No peculiar reaction
Acetic acid (CH ₃ COOH, 3%)	No peculiar reaction
Acetic acid (CH ₃ CH ₂ OH, 15%)	No peculiar reaction
Vegetable oil	No peculiar reaction

Migration analyses of substances into food with 4 representative solutions: (Methods ASU § 64 LFGB B-80.30-2 EG, RL 82/711/EWG)

Mechanical properties

	BALITHERM® IONIT ST
Surface treatment	Nitrogen diffusion zone
Micro hardness (HV0.1)	1,000 - 1,200
Typical thickness	10 - 20 µm
Colour	Silver grey

Open a new world of possibilities with BALITHERM IONIT ST Contact us today!

Headquarters

Oerlikon Balzers Coating AG
Balzers Technology & Service Centre
Iramali 18
9496 Balzers
Liechtenstein
T +423 388 7500

China

Oerlikon Balzers Coating
(Suzhou) Co., Ltd
No. 9 Changyang street
Suzhou Industry Park
Jiangsu Province
Suzhou 215024
China
T +86 512 67620369

Oerlikon Metco Surface
Technology (Shanghai) Co., Ltd.
B1 & B2, No. 539, Baian Road,
Anting
Jiading District
Shanghai 201814
China
T +86 21 67087000

Germany

Oerlikon Balzers Coating
Germany GmbH
Hohe-Flum-Straße 22
79650 Schopfheim
Germany
T +49 76 22 39 99-0

Oerlikon Metaplas GmbH
Theodor-Heuss-Straße 63
38228 Salzgitter
Germany
T +49 5341 8587-0

Oerlikon Metaplas GmbH
Am Böttcherberg 30 – 38
51427 Bergisch Gladbach
Germany
T +49 2204 299-0

Japan

Oerlikon Nihon Balzers
Coating Co., Ltd.
Shizuoka Factory
1110-10 Kamo
Shizuoka Pref.
Kikugawa-City 439-0031
Japan
T +81 537 35 8805

Korea

Oerlikon Balzers Coating
Korea Co., Ltd.
66, Gwahaksandan 1-ro
Gangseo-gu
Busan 618-230
South Korea
T +82 51 974 9900

USA

Oerlikon Balzers Coating USA, Inc.
109 Parkway East
Pell City, AL 35125
United States
T +1 205 884 1210

You can find a full listing
of our locations at:

www.oerlikon.com/balzers