

Creating a global technology leader in surface solutions

Media & Analyst Conference

Zurich

June 3, 2014



- 1 Transaction rationale**
- 2 Financial impact
- 3 Integration
- 4 It's all about growth – future potential
- 5 Summary
- 6 Q&A

The merger of Balzers and Metco will form a global technology leader in surface solutions

Surface Solutions Segment



NITRIDING

- Plasma Nitriding

THIN FILM COATING

- PVD
- PECVD (PACVD)

THICK LAYER COATING

- Thermal Spray

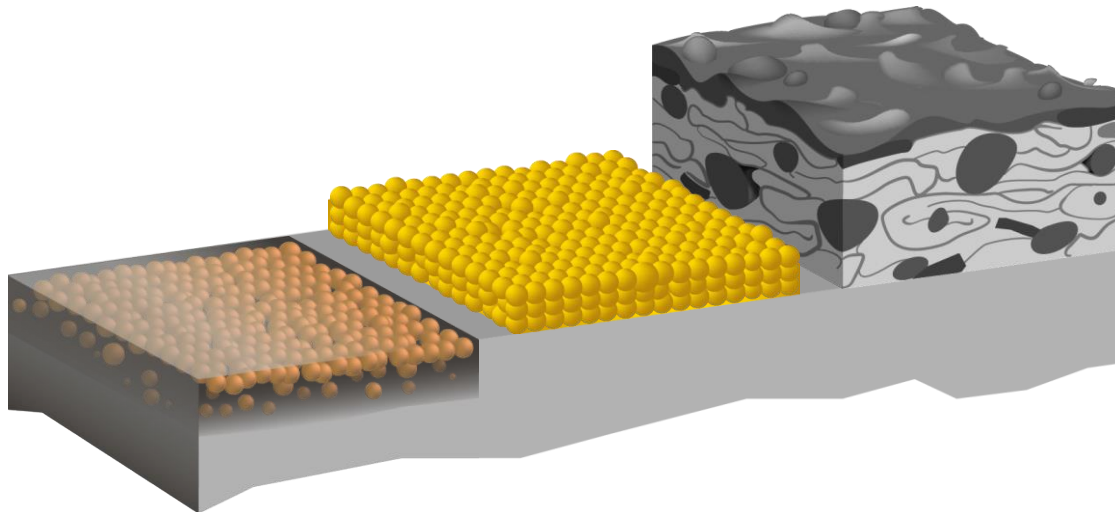

Transaction summary

- Signing Jan. 30, 2014
- Closing June 2, 2014
- Enterprise value of CHF 1 bn
- Forms the Surface Solutions Segment
- Surface Solutions to become largest Segment of Oerlikon Group
- Represents the latest step in Oerlikon's transformation process
- Positions the Group for long term profitable growth

High growth surface technologies still at an early stage



Focus on surface solutions:

- Attractive market potential
- Growth above industrial average
- Environmentally friendly

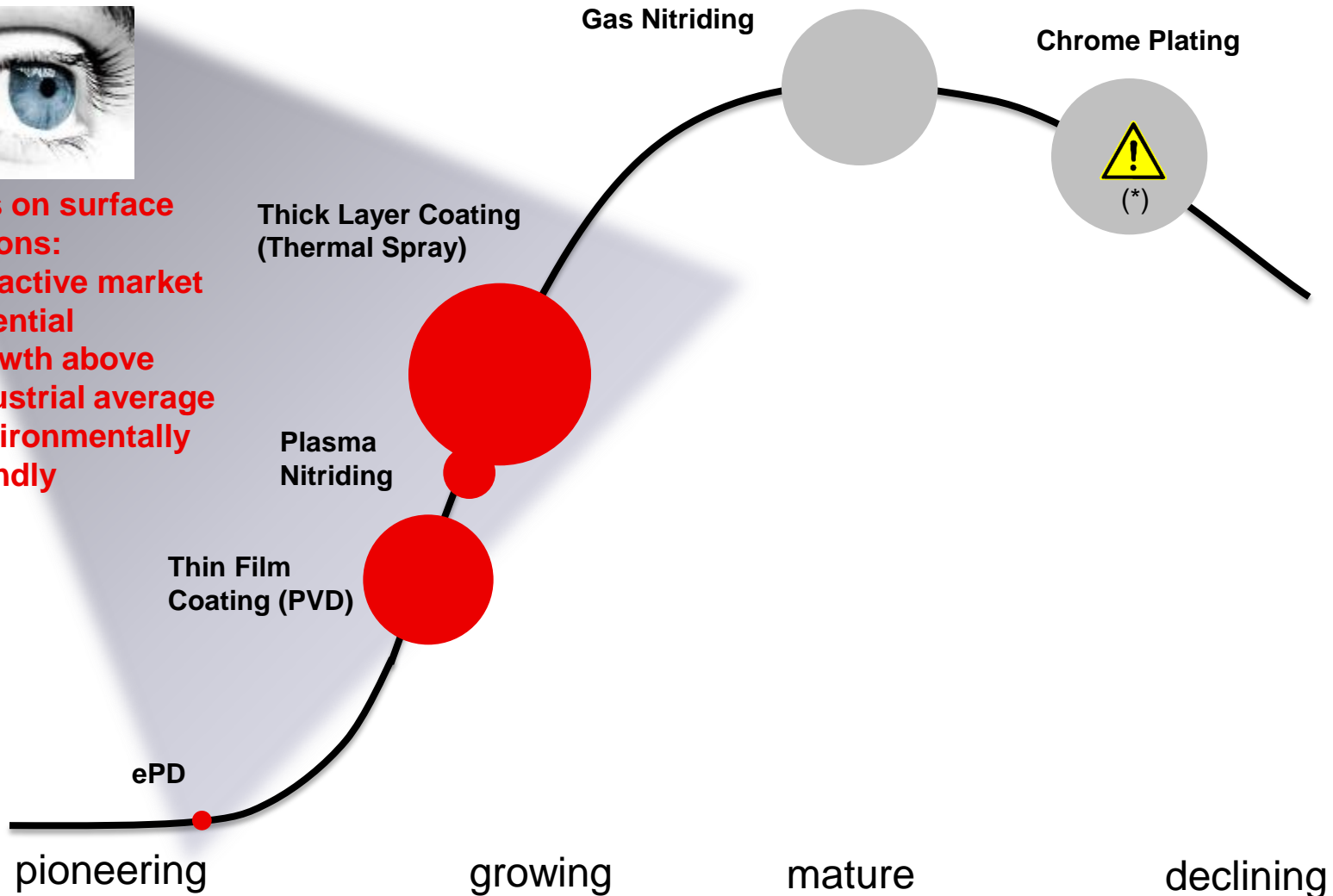

* Hazardous production process

Beginning of a new era: Complementary technologies with unique product and service offering

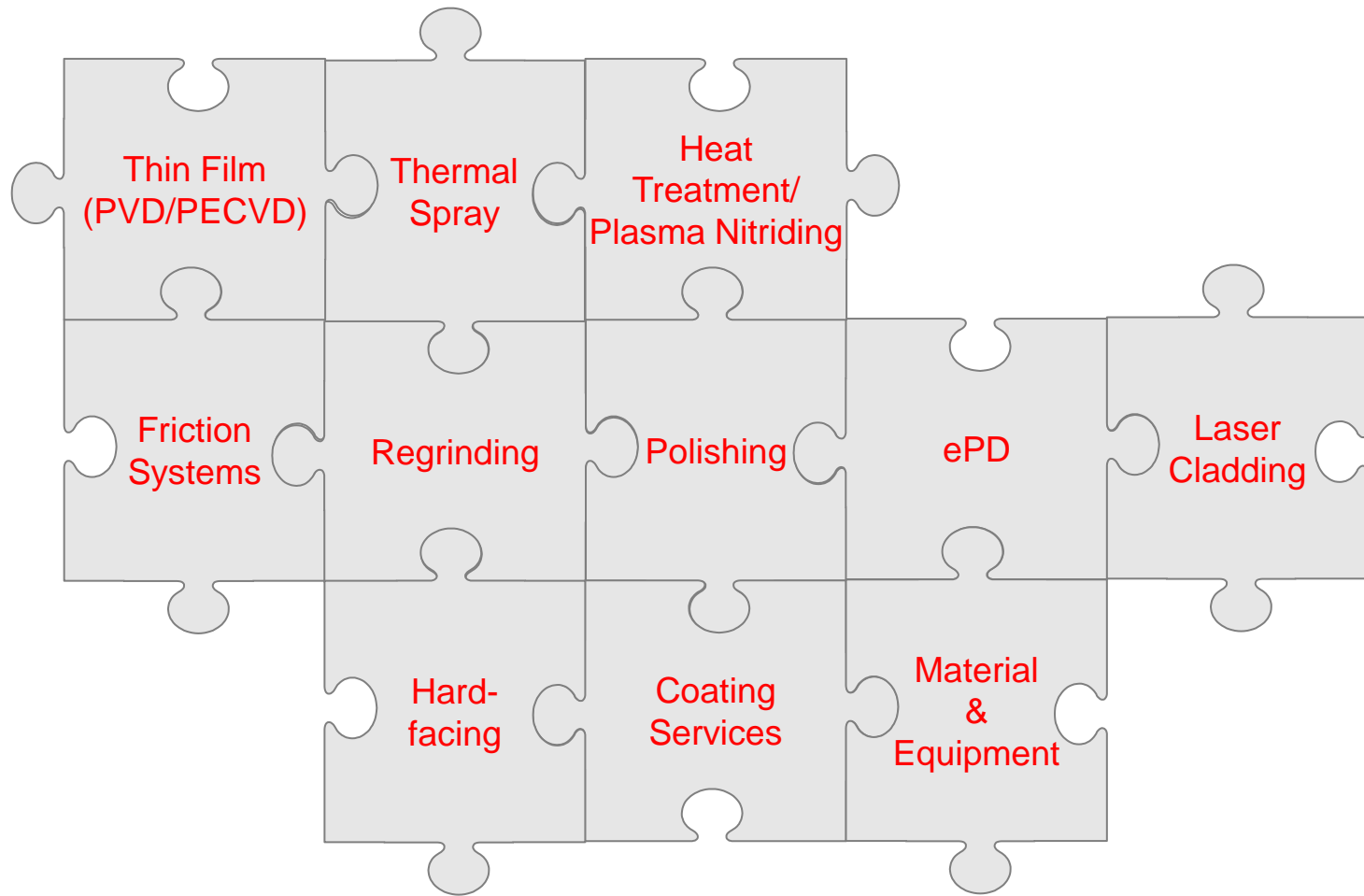

Key rationale – Creating a global technology leader in Surface Solutions

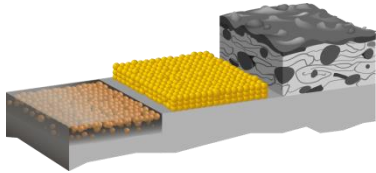

Combining leading surface technologies

- Balzers with the leading position in Thin Film Coating
- Metco with the leading position in Thermal Spray
- Adjacent technologies create a unique global product and service portfolio
- Customers will be able to develop the best surface solution with one single partner / R&D team



Business model

- Balzers with dedicated service business model and service DNA
- Metco focused on providing equipment and materials
- Strengthening the Thermal Spray and Plasma Nitriding services through Balzers' proven service experience and global network



Access to end markets

- Increase addressable market to some CHF 9 billion with attractive forecasted growth of more than 5% p.a.
- Balzers with strong position in automotive, tooling & general industry
- Deepening access to end markets like aerospace and power generation using Metco's applications know-how



Leverage service footprint

- Combined network of over 110 coating centers worldwide
- Globally balanced footprint
- Leverage stronger Metco footprint in the US
- Balzers' established position in China and India to support market access for Metco

Surface Solutions Segment with the potential to outperform underlying industry growth



CAGR: ~6 %

Aviation



CAGR: ~5 %

Automotive



CAGR: ~4 %

Oil & Gas



CAGR: ~5 %

Tooling



CAGR: ~5 %

Power Generation



CAGR: ~4 %

General Industry

Global GDP growth: around 3 %

1 Transaction rationale

2 Financial impact

3 Integration

4 It's all about growth – future potential

5 Summary

6 Q&A

A more balanced Oerlikon portfolio – Surface Solutions becomes the largest Segment

Oerlikon Group

(FY 2013 reported)

Oerlikon Group incl. Metco

(FY 2013 pro forma figures)

Sales

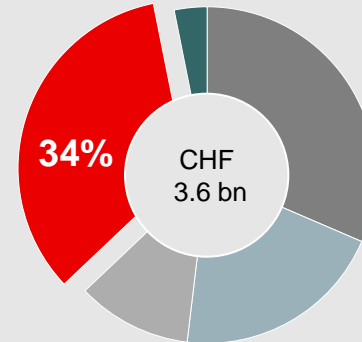
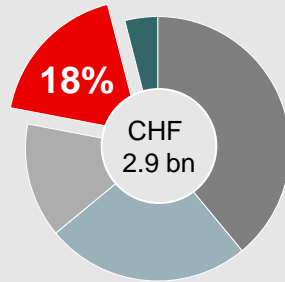

EBITDA

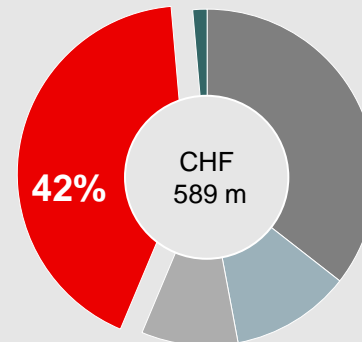
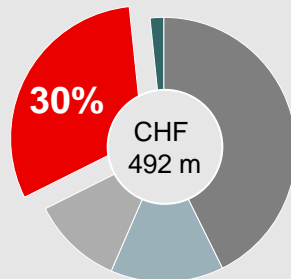

Manmade Fibers
 Drive Systems
 Vacuum
 Coating / Surface Solutions
 Advanced Technologies

Strong post transaction balance sheet leaves room for organic and inorganic growth

Financing of transaction

in CHF million

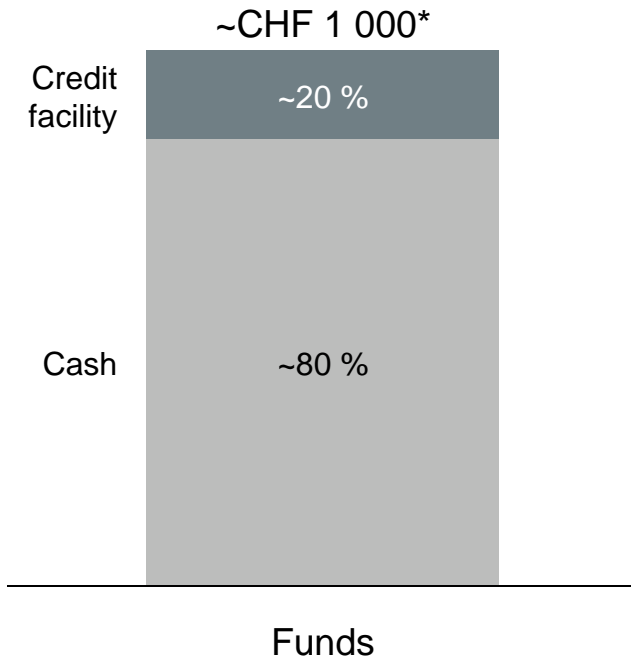

- Following settlement of new Bonds, Oerlikon might consider to repay credit facility to optimize financial structure and financing costs

Balance sheet post Metco transaction (normalized)

in CHF million (Coupon)

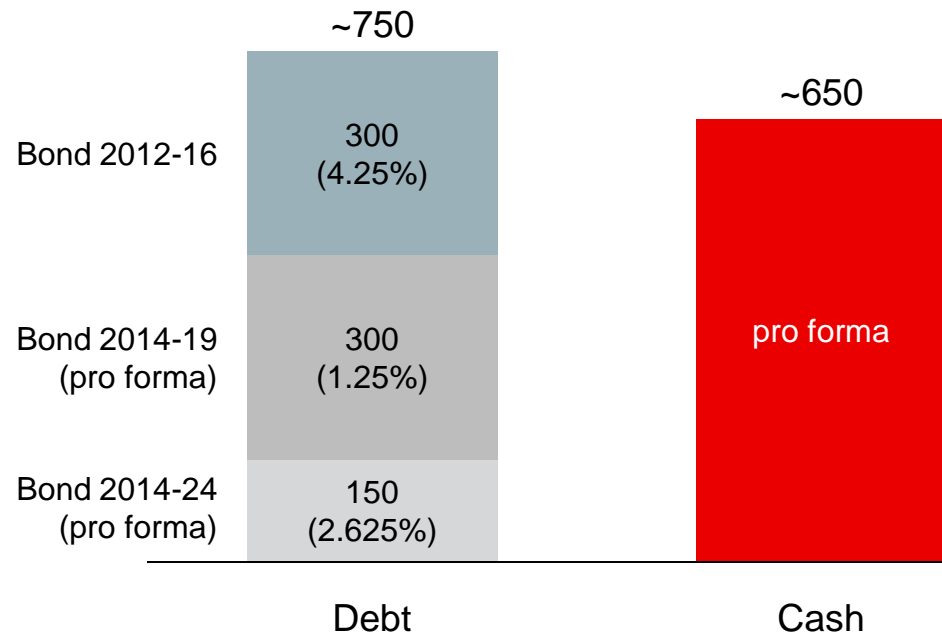

- Net debt post transaction of approx. CHF 100 million
- Pro forma net debt / LTM EBITDA of ~0.2 maintains financial flexibility

* Preliminary; subject to final adjustments

Financial impact of transaction

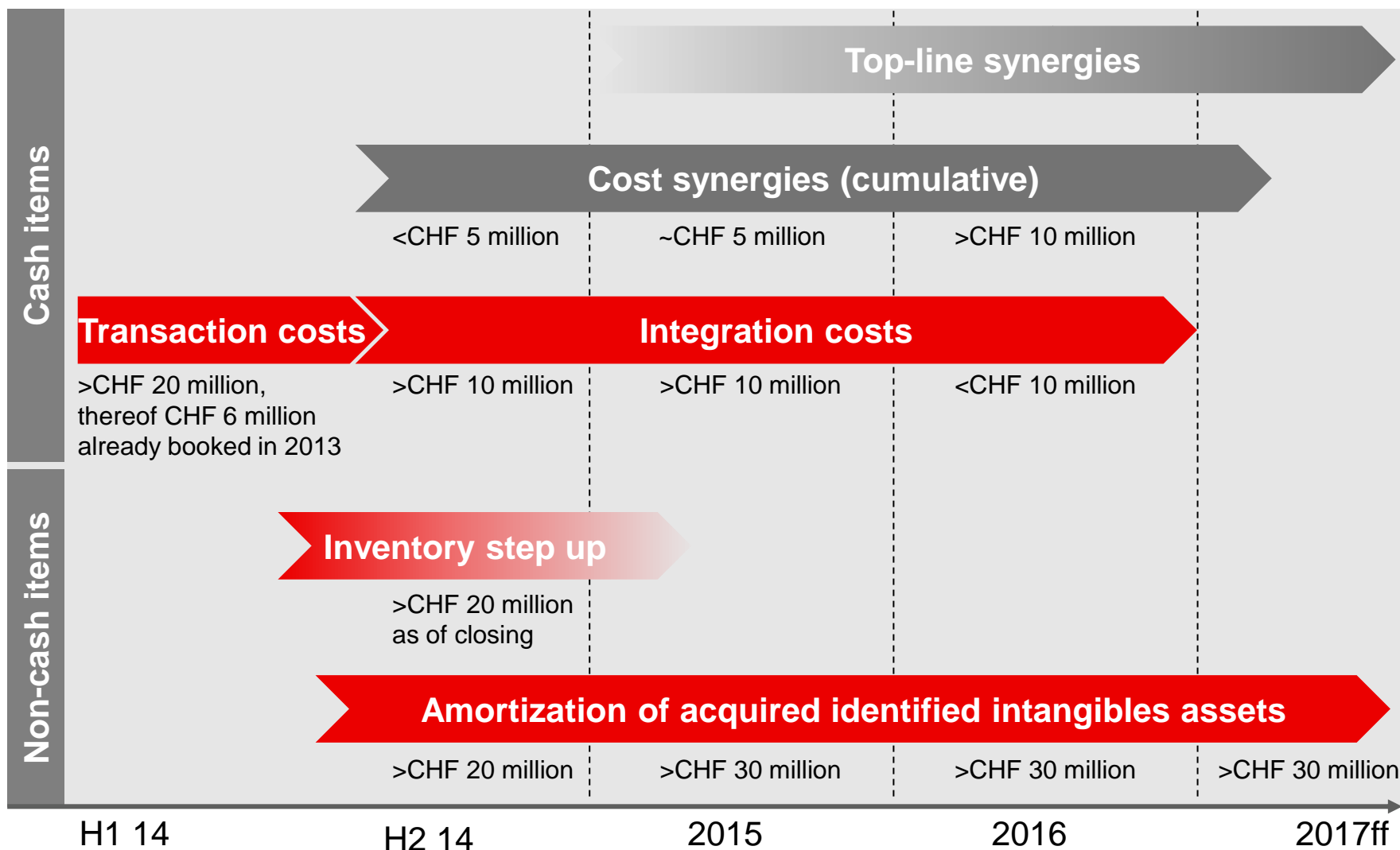

Change in guidance to increase transparency

Previous:



Interim:



As of fiscal year 2015:

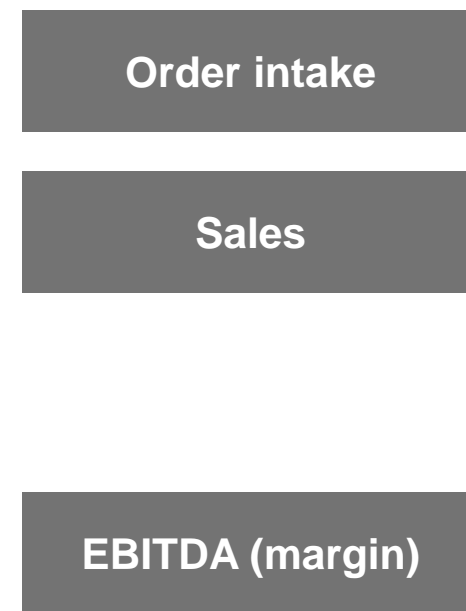

- EBITDA instead of EBIT guidance as of fiscal year 2015
- EBITDA provides better insights into the underlying performance
- EBIT impacted by amortization of acquired identified intangible assets (non-cash)
- To ensure a smooth transition, Oerlikon will provide both EBIT and EBITDA guidance for fiscal year 2014



2014 Group Guidance

Based on the existing confirmed guidance pre Metco and consolidating Metco for seven months, Oerlikon expects compared to 2013 reported figures:

- Order intake growth of around 10 %
- Sales growth exceeding 15 %
- EBIT* margin of around 10 %
- EBITDA* margin of around 15 %

* including full absorption of all related transaction/integration costs and accounting effects

1 Growing demand for Surface Solutions

2 Financial impact

3 Integration

4 It's all about growth – future potential

5 Summary

6 Q&A

oerlikon

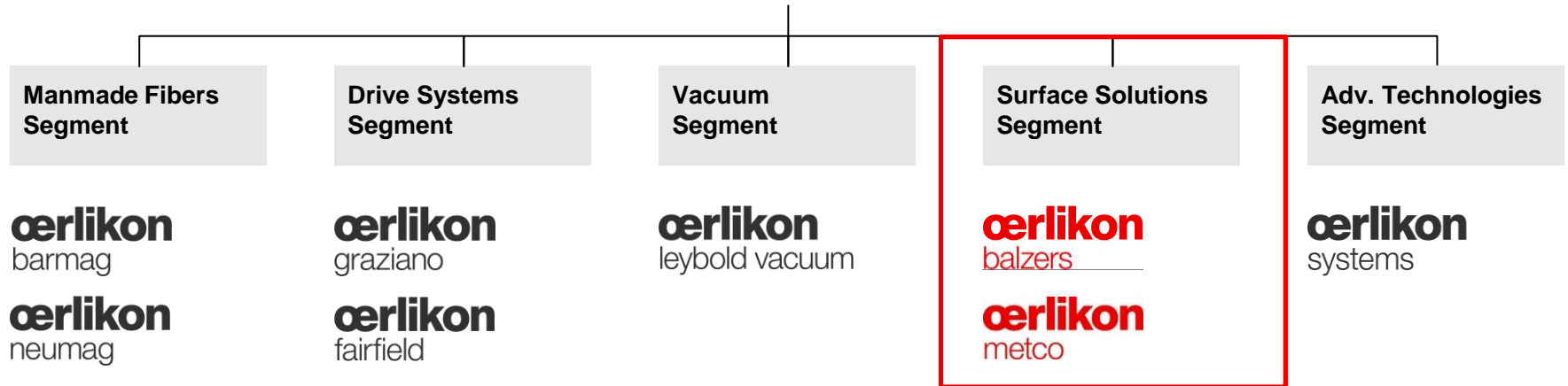

Organization/ Brands

- Dr. Roland Herb appointed as CEO of the Surface Solutions Segment
- Bernd Fischer appointed Head of BU Oerlikon Balzers
- Thomas Gutzwiller appointed Head of BU Oerlikon Metco
- Take over of all Metco employees

- Surface Solutions & Oerlikon Balzers will be, respectively remain headquartered in Balzers
- Oerlikon Metco remains headquartered in Winterthur
- Surface Solutions to build on the strong brands of Oerlikon Balzers and Oerlikon Metco

- 1 Growing demand for Surface Solutions
- 2 Financial impact
- 3 Integration
- 4 It's all about growth – future potential**
- 5 Summary
- 6 Q&A

Surface solutions becoming key design element to meet growing requirements



Productivity



Environmental Friendly



Energy Efficiency



Performance

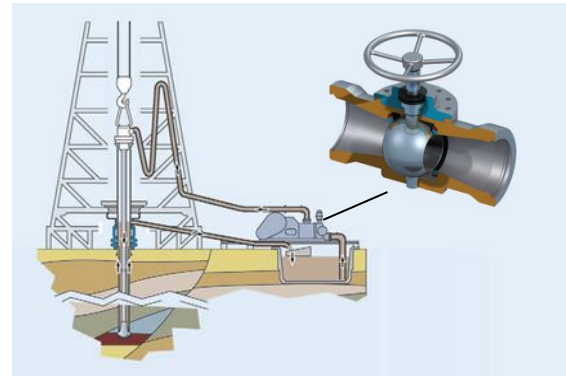

Reliability



Design

Oerlikon's surface solutions as environmentally friendly alternative to Chrome Plating

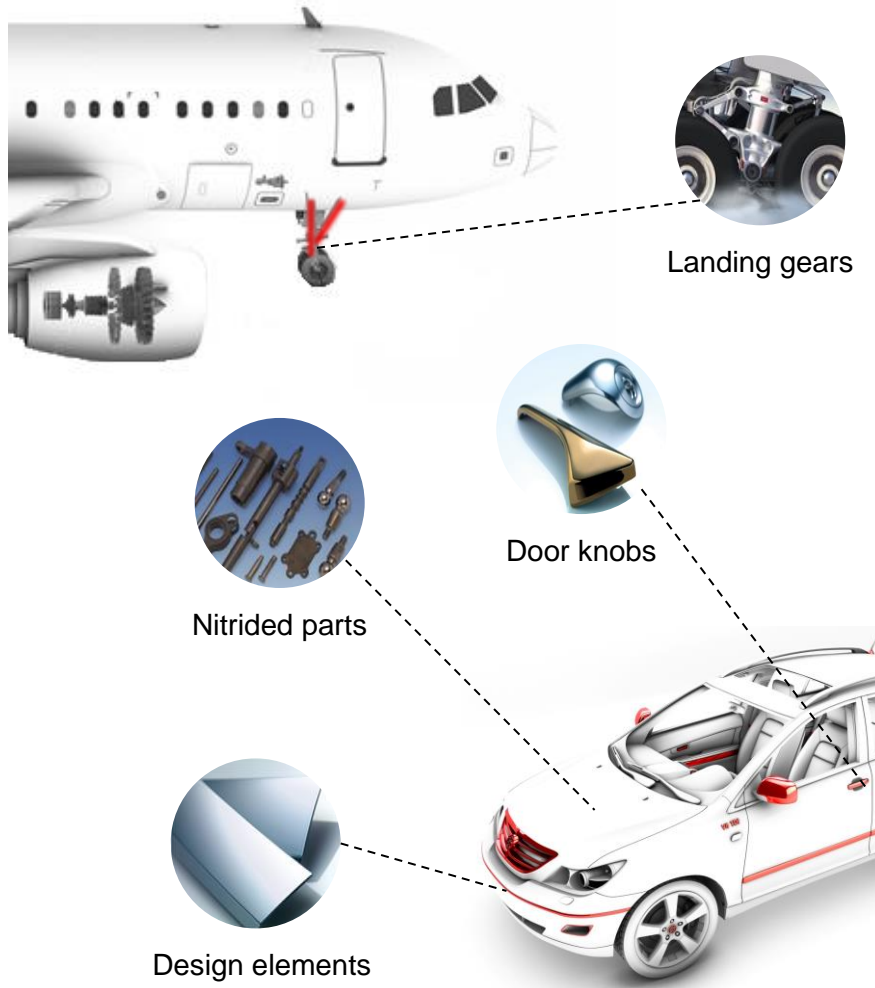

Challenge:

Hexavalent chrome (Cr VI) as a key ingredient in the Chrome Plating process is of high concern for environment and operator health (carcinogen)

Solution:

Environmentally friendly surface solutions based on Thin Film and Thermal Spray coatings

Oerlikon's contribution:

The Surface Solutions Segment is a global technology leader in the major substitution technologies

- Thermal Spray technology
- Plasma Nitriding (e.g. PPD¹)
- Thin Film
- ePD²

¹ PPD: Pulsed Plasma Diffusion; ² ePD: Embedded PVD for Design parts

One face to the customer... ...in the aviation industry

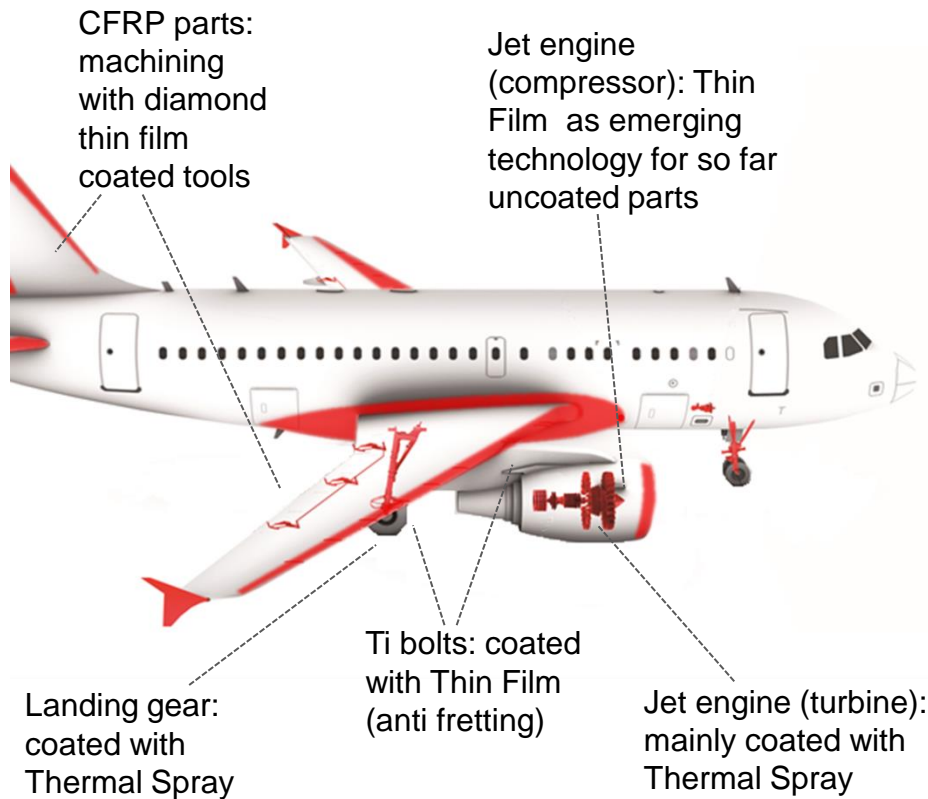

Challenge:

- Steadily increasing demand for fuel efficiency asks for
 - more efficient engines
 - lighter materials
- Steadily increasing demand for environmentally friendlier processes asks for
 - replacement of Chrome Plating
 - replacement of Cadmium

Solution:

Thin Film and Thermal Spray coatings as economic alternatives to Hard Chrome

Oerlikon's contribution:

As a global technology leader the Segment Surface Solutions offers the relevant solutions:

- Thermal Spray
- Plasma Nitriding
- Thin Film (including Diamond coatings on tools)

One face to the customer... ...in the automotive industry

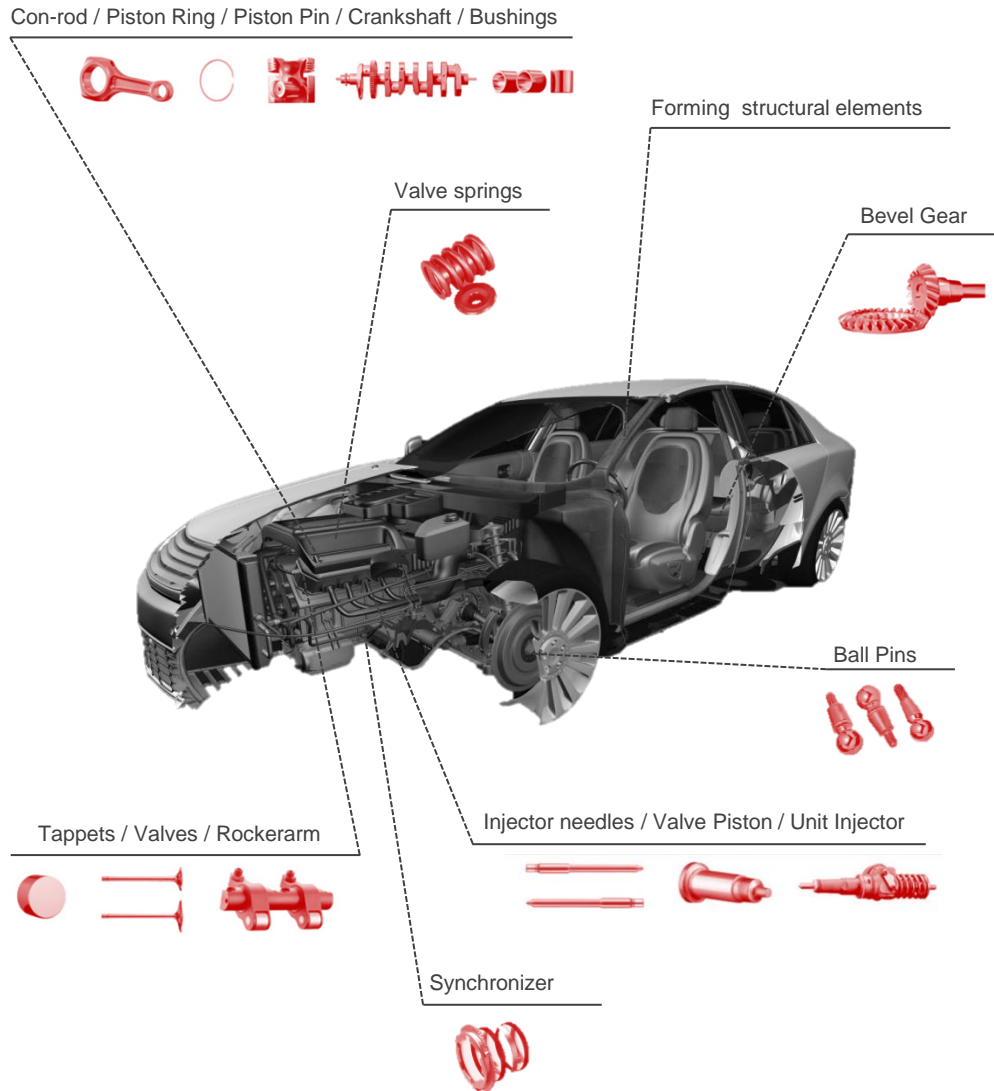

Challenge:

Steadily increasing demand for environmentally friendlier cars at lowest possible costs asks for:

- Increasing fuel efficiency
- Reducing emissions
- Increasing efficiency in production

Solution:

Plasma Nitriding, Thin Film and Thermal Spray solutions on components and production tools

Oerlikon's contribution:

As a global technology leader the Surface Solutions Segment offers the relevant solutions:

- Thin Film
- Plasma Nitriding
- Thermal Spray

One face to the customer... ...in the oil & gas industry

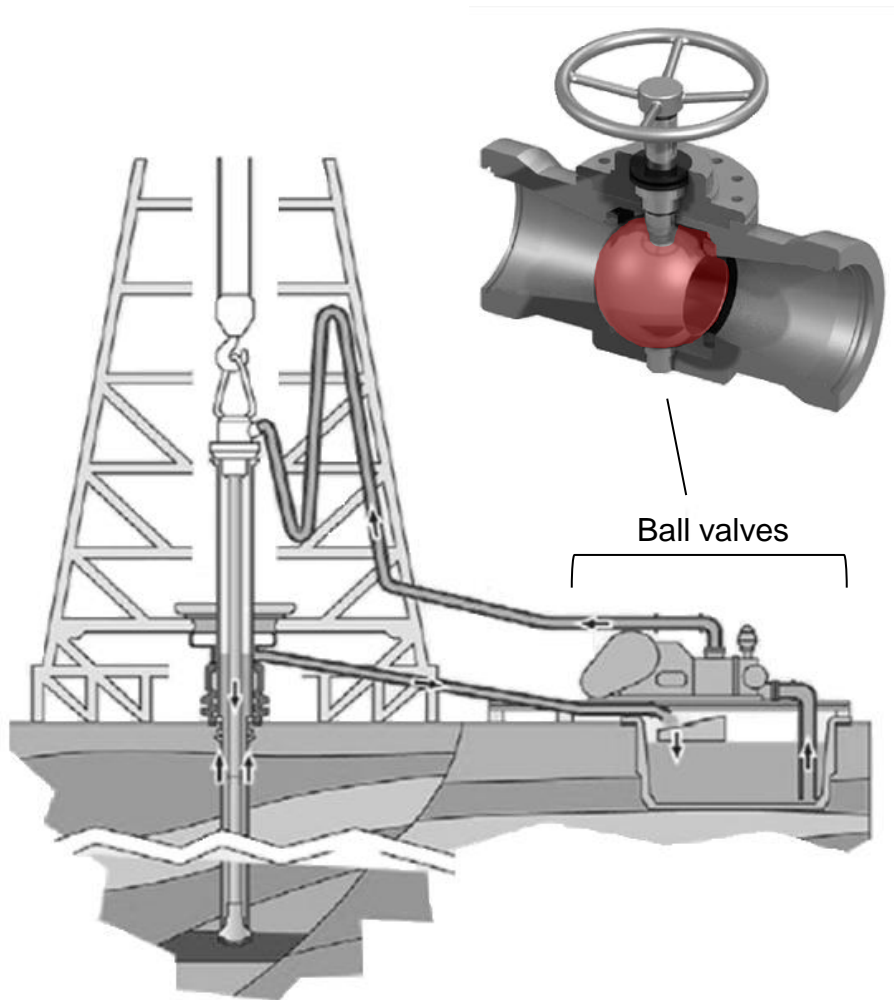

Challenge:

Steadily increasing demand for reliability asks for

- Increased safety buffer
- Increased performance through reduced leakage and backflow
- Increased uptime

Solution:

Thermal Spray and Thin Film solutions to protect against galling, abrasion, and erosion under extreme conditions

Oerlikon's contribution:

As a global technology leader the Surface Solutions Segment offers the relevant solutions:

- Thermal Spray
- Thin Film
- Plasma Nitriding

- 1 Growing demand for Surface Solutions
- 2 Financial impact
- 3 Integration
- 4 It's all about growth – future potential
- 5 Summary**
- 6 Q&A

- Creating a global technology leader in surface solutions with unique global product and service portfolio
- Complementarity of Oerlikon Balzers and Oerlikon Metco
 - ✓ Technology
 - ✓ Business model
 - ✓ End market exposure
 - ✓ Global footprint
- Strong and experienced management team
- Strategic investment along a consistent Group strategy
- Financial flexibility to support on agenda of long-term profitable growth



Beginning of a new era: Oerlikon Balzers and Oerlikon Metco form a new global technology leader in surface solutions.