

oerlikon
barmag

PROFIN

Spin-finish pumps

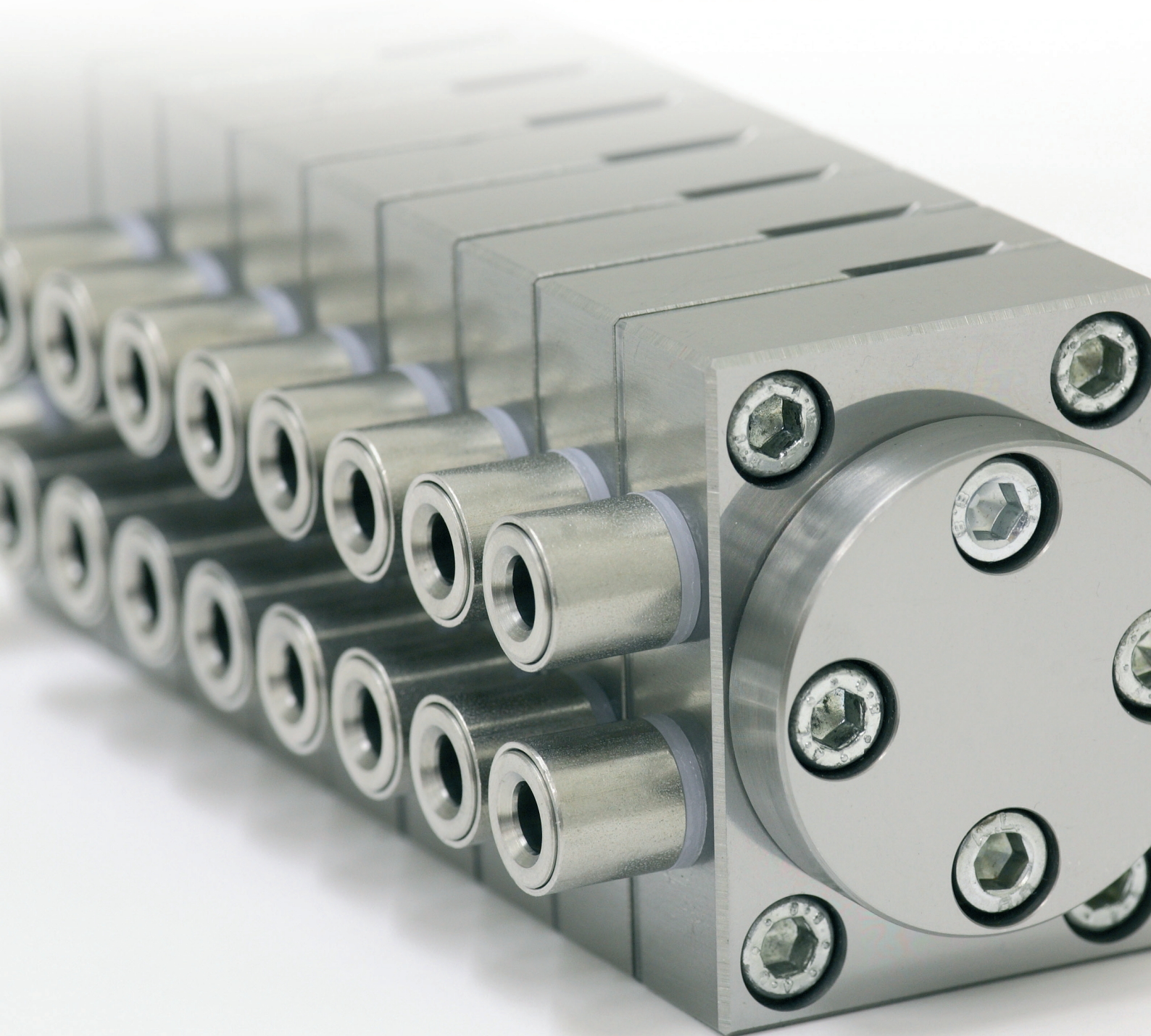

Invest in your machine life

Features

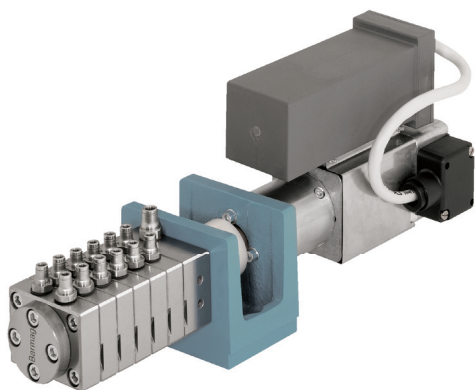

The worldwide success of Oerlikon Barmag spin-finish pumps continues with a new series which, once again, sets distinctly higher standards in regard to feed accuracy, operating stability, and service life of the equipment.

The PROFIN series is designed for use with all commercially available types of spin finish, from high down to low oil concentration. In addition, the production program includes pumps specifically tailored to handle corrosive spin-finish liquids. Identical connection dimensions of the PROFIN spin finish pumps permit exchange with those of the previous series.

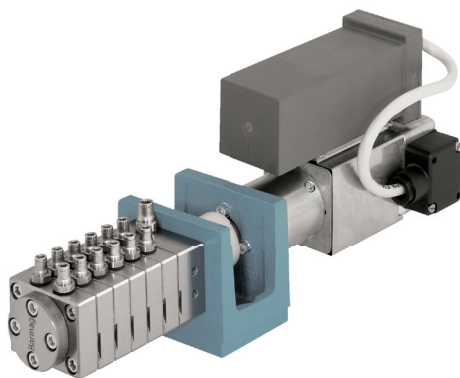

The drive with brushless three-phase motor and integrated inverter is standard in Oerlikon Barmag spinning lines. The inverter installed directly at the three-phase motor ensures sepa-

rate speed control for each individual PROFIN pump and, therefore, flexible setting of the spin finish throughput volume per spinning position.

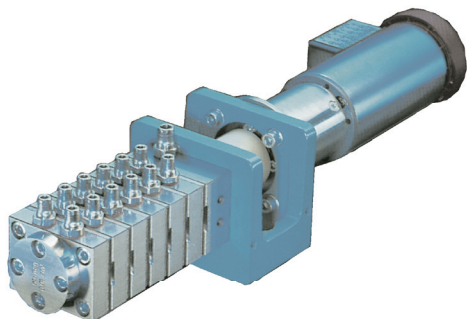

The drive with synchronous motor is suitable for installation – or retrofitting – in lines in which multiple pump drives are controlled by single frequency inverter. In this configuration,

the so-called group drive permits only common speed control of the drives; switching ON and OFF can, however, be done per individual position.

Your success is in the detail

Design

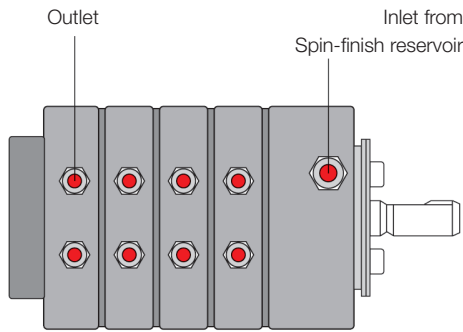

Modular system

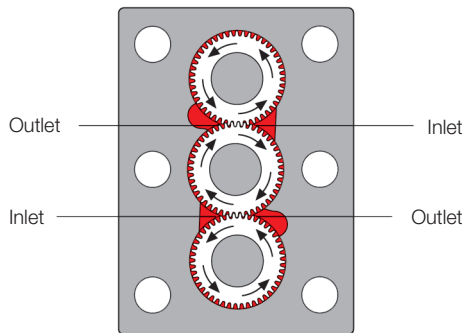

Metering level

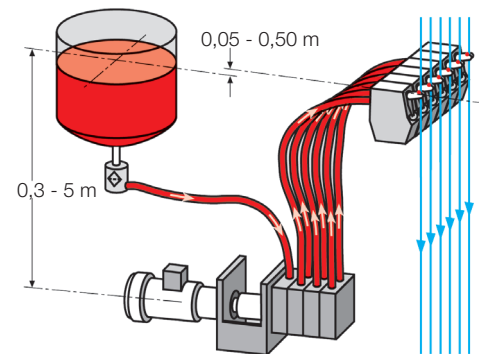

Layout in the machine

PROFIN spin-finish pumps are equipped with one central inlet and two outlets for each plate level. They are available with 2 to 16 outlet channels. The positions of inlet and outlet ports can depend on the positioning either on the top or the side of the pump. Oerlikon Barmag's preference is to arrange the pump for connection from the top.

The more evenly the spin finish liquid is applied to the yarn, the better the yarn quality.

We recommend keeping the pressure differential between pump inlet and outlet as low as possible. The spin-finish nozzles should be located 50 – 500 mm above the level of the liquid in the reservoir. The input height to the

pump should be at least 300 mm (see diagram at top right). PROFIN Spin-finish pumps are designed for 7-70 rpm. Depending on the viscosity of the spin-finish liquid, the usual speed range is between 15 and 60 rpm.

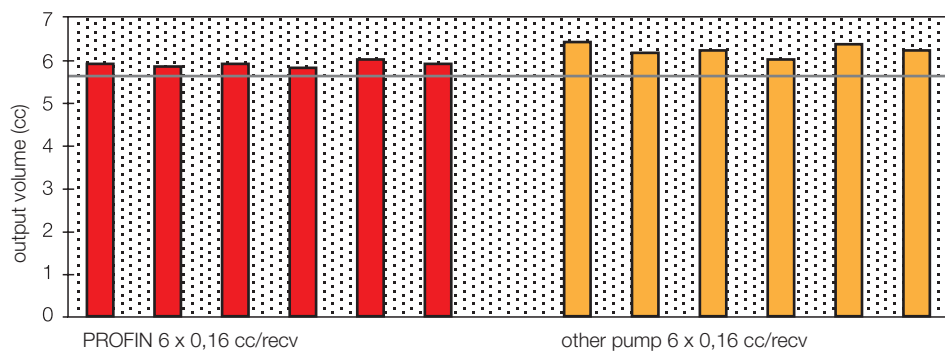

The narrow feed tolerance range of the PROFIN pump ensures a distinctly longer lifetime of the pump.

So you get better and better Quality

$$F = \frac{mf \times oL}{\rho \times n \times cL \times N}$$

- F pump volume [ccm/rev]
- mf throughput per yarn end [g/min]
- ρ solution density [g/ccm]
- n pump speeds [rpm]
(recommended pump speed 15-60 rpm)
- cL solution concentration [%]
- oL oil pick up [%]
- N number of spin finish nozzles per yarn end

Calculating the optimal pump capacity

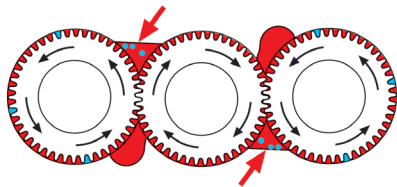

Self venting channels

The special design of the inlet channels prevents accumulation of micro bubbles and ensures continuous uniform wetting of the yarn. This spin finish pump does not have any dead spaces and is self-venting.

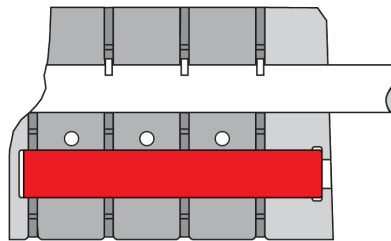

Fully supporting pivot

The driven gears of the PROFIN pump are 100% supported. All driven gears are arranged on a continuous pivot, regardless whether 2 or 16 outlets. This design keeps the gear wheel from „running in“, thus preventing inaccuracies in the spin-finish metering process.

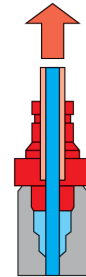

Pipe fittings

For connection of the inlet and outlet pipes, stainless steel fittings without dead spaces are available. When using the quick-connectors, the pump and pipes can be connected to – or disconnected from – each other quickly and without any tool.



Test stand

For continual quality assurance at the operating site, a test stand has been developed to check the feed accuracy after extended operation or after maintenance, for example. The stand permits testing under a variety of operating conditions (pressures, speeds, viscosities).

Focus on your core business

Advantages

Long service life

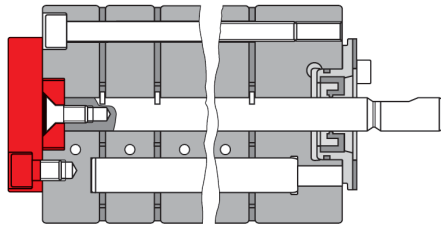

The PROFIN spin-finish pump is equipped with a back pressure plate which absorbs the axial load in both directions. Special surface treatment of the side plates increases resistance to tribo-oxidation.

Operator – friendly

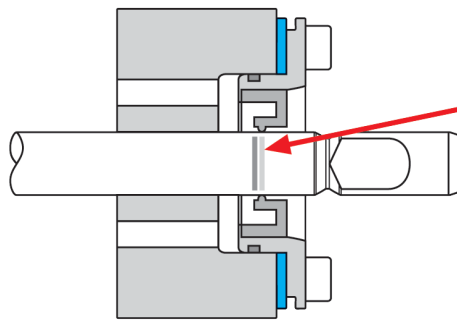

The mounting design for the shaft sealing ring doubles its service life. Exchange is simple and does not require removal of the shaft. In its new position it is once again completely leakproof.

Operating stability

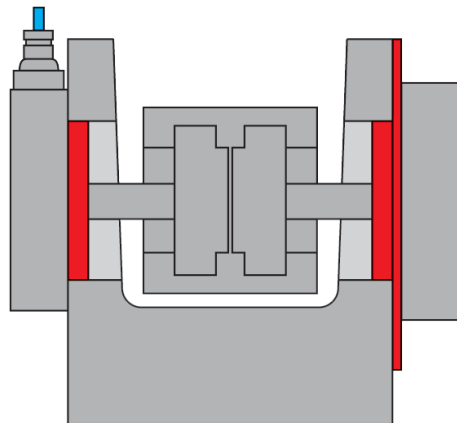

Centering devices on pump and motor permit a simple pump assembly which is concentric in relation to the drive. This feature reduces the risk of misalignment and consequent wear.

Quality



REG. NR. 3603-01

Development, design, manufacture, and assembly meet the highest quality standards and fulfill the requirements of a certified quality management system. Each pump is subjected to a quality control flow test. This test verifies the throughput accurating as well as drive torque.

Special packing ensures safe transport and storage at the installation site.

Oerlikon Barmag

Zweigniederlassung der
Oerlikon Textile GmbH & Co. KG
Leverkuser Straße 65
42897 Remscheid
GERMANY
Phone +49 21 91 67-0
Fax +49 21 91 67-12 04
www.pumps.barmag.oerlikontextile.com
pumpsales@barmag.de

Oerlikon Textile Inc.

8805 South Boulevard
Charlotte N.C. 28273
U.S.A.
Phone +1 704 916 42 68
Fax +1 704 916 42 09
info.charlotte@oerlikon.com

Oerlikon Textile Far East Ltd.

Room 3608, 36 F,
China Resources Building
26 Harbour Road
Wanchai / Hongkong
HONG KONG
VR.CHINA
Phone +852 28 27 43 14
Fax +852 28 27 52 50
info.textile.hk@oerlikon.com

Oerlikon Textile India Pvt. Ltd

Empire Industries Complex
414, Senapati Bapat Marg
Lower Parel (West)
Mumbai-400013
INDIA
Phone +91 22 3351 79 00
Fax +91 22 3351 79 05
management.bom@oerlikon.com

The information supplied in this
brochure is for guidance only.
We reserve the right to modify it
at any time.