

**oerlikon**  
barmag

# Precision gear metering pumps

For paint applications

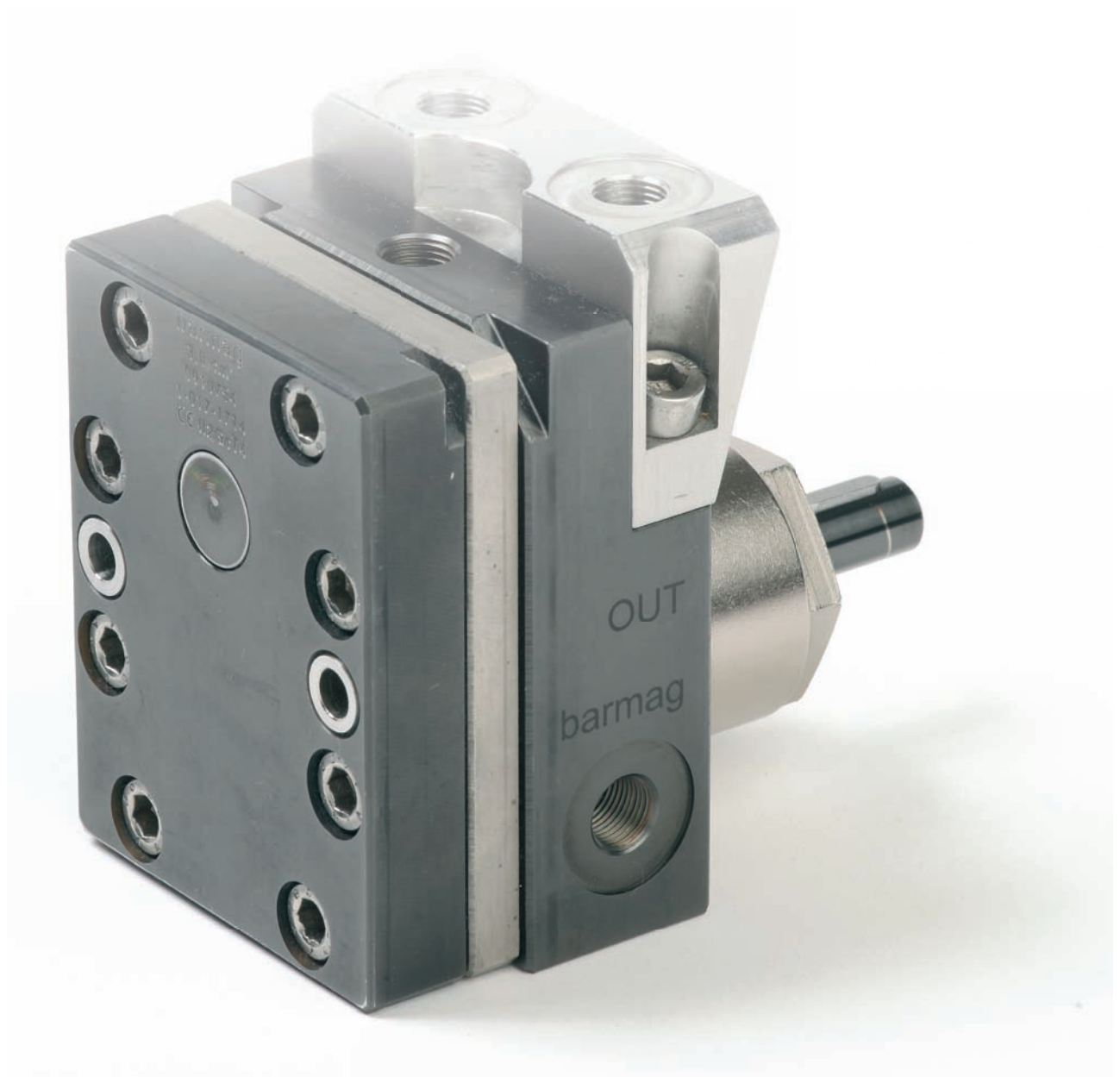

# For brilliant performance – gear metering pumps from Oerlikon Barmag make paint systems even more efficient

Oerlikon Barmag has been manufacturing precision gear metering pumps since the company was founded in 1922.

Since gear metering pumps for metered surface coatings and paints were added to the company's product portfolio in 1985, Oerlikon Barmag has more than 50,000 paint metering pumps in operation throughout the world, which are increasingly being deployed in surfacing technology application systems. They are used to efficiently apply paints in various industrial applications, such as in the production of automobiles, in the aerospace industry or in the manufacture of components used for generating renewable energies.

In many of these manufacturing processes, applying paint to the finished product is often one of the most challenging tasks. Here, it is all about highly-efficient paint systems applying paints flawlessly – both in terms of look and feel – and ensuring that the appli-

cation complies with the every higher durability demands for the end product.

The high-precision gear metering pumps from Oerlikon Barmag enable the paint systems' applications to carry this out with a high degree of reliability. Among other things, the pumps excel in terms of their flow-enhancing construction and absence of dead spots. These are the fundamental prerequisites for short flushing times and low consumption of flushing agents and hence for the friendly handling of resources.

The smallest tolerances and reproducible quality in the manufacture of the gears and their enveloping gear plate have the greatest influence on conveying accuracy. In turn, these are responsible for the quality of the end product's coating.

The range of GP paint metering pumps has been developed for universal deployment with solvent-based and

water-based paints. The pumps are manufactured in a special non-corrosive and acid-resistant steel. During wear-intensive metering of metallic paints, for instance, the DLC wear-protection layer provides the pumps with extended durability. When using heavily-wearing paints, ceramic components can be additionally used to increase the service life of pumps.

Fast paint changes are possible as a result of the tooth flank and bearing flushing features of the metering pump. The delivery program also includes the flushing block, which is identical for all pump sizes and is equipped with appropriate connection adaptors for solvent feed and air pressure. The weight-optimized metering pumps – available for capacities of between 1.2 cm<sup>3</sup>/revolution and 9 cm<sup>3</sup>/revolution – can be exchanged 1:1.

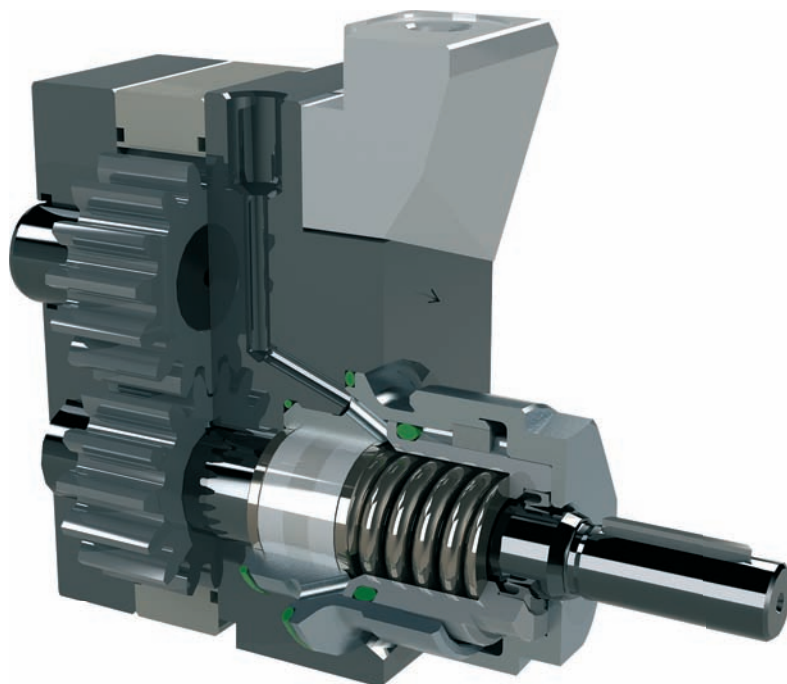

GP paint metering pumps with spring-preloaded stuffing box for low-maintenance shaft sealing.

# Metering with the highest precision

## Highlights

- Variability by various pressure sensor blocks
- Extended service life time by
  - DLC wear-protection layer
  - Optimized orientation of the plate package
  - Utilization of ceramic components (optional)
- Lower weight time by
  - Compact design
  - Utilization of light metal sealing components
- Seal system
  - Spring-preloaded stuffing box, prepared for using buffer fluid
  - O-ring sealed plate package

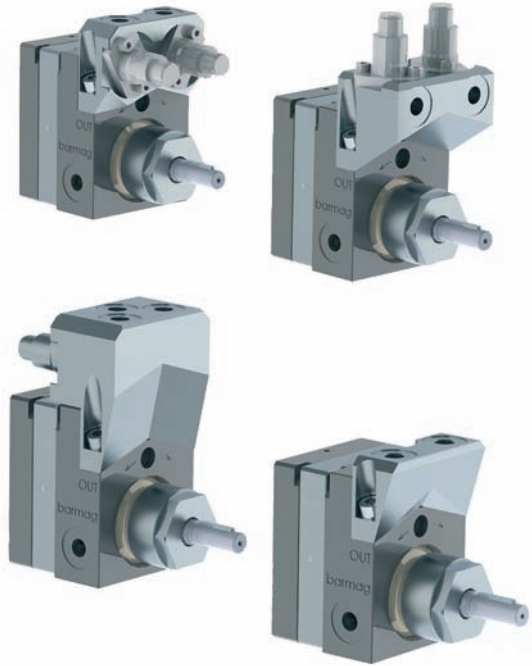

A selection of flexibly, replaceable pressure sensor blocks is available to realize different installation situations

## Accessories

- ATEX certificate
- Pressure sensors for monitoring inlet and outlet pressures for even metering
- Flushing technology
  - Flushing block for tooth flank flushing
  - Flushing block for tooth flank- and bearing flushing

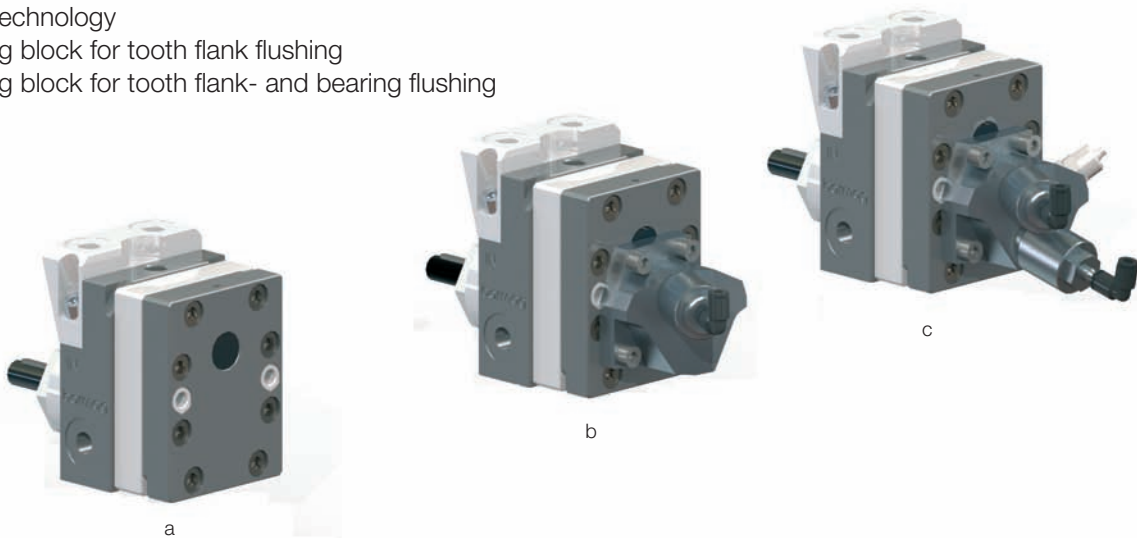

GP paint metering pump

- a Non-flushable
- b With flushing valve for tooth flank flushing
- c With flushing valve for tooth flank and bearing flushing

**Oerlikon Barmag**

Zweigniederlassung der  
Oerlikon Textile GmbH & Co. KG  
Leverkuser Straße 65  
P.O. Box 11 0240  
D-42862 Remscheid  
GERMANY  
Phone +49 21 91 67-0  
Fax +49 21 91 67-12 04  
[www.oerlikon.com/manmade-fibers](http://www.oerlikon.com/manmade-fibers)  
[pumpsales.barmag.oerlikon.com](http://pumpsales.barmag.oerlikon.com)

**Oerlikon Textile Inc.**

8801 South Boulevard  
P.O. Box 70 46  
Charlotte N.C. 28241  
U.S.A.  
Phone +1 704 910 42 68  
Fax +1 704 910 42 09  
[info.charlotte@oerlikon.com](mailto:info.charlotte@oerlikon.com)

**Oerlikon Textile Far East Ltd.**

Room 2806  
China Resources Building  
26 Harbour Road, 28 / F  
Wanchai, HONG KONG  
P.R.CHINA  
Phone +852 28 27 43 14  
Fax +852 28 27 52 50  
[info.textile.hk@oerlikon.com](mailto:info.textile.hk@oerlikon.com)

**Oerlikon Textile India Pvt. Ltd.**

Empire Industries Complex  
414, Senapati Bapat Marg  
Lower Parel (West)  
Mumbai-400013  
INDIA  
Phone +91 22 6652 7900  
Fax +91 22 6652 7901  
[management.bom@oerlikon.com](mailto:management.bom@oerlikon.com)

The information supplied in this  
brochure is for guidance only.  
We reserve the right to modify it  
at any time.

OBA 112 e / 01/2014  
Studio 45 / Köllen Druck & Verlag, Bonn  
Subject to changes