

BALITHERM IONIT & IONIT OX

in automobiles



Connecting rods / Piston rings / Piston pins / Crankshafts / Sockets



Valve springs



Bevel gears

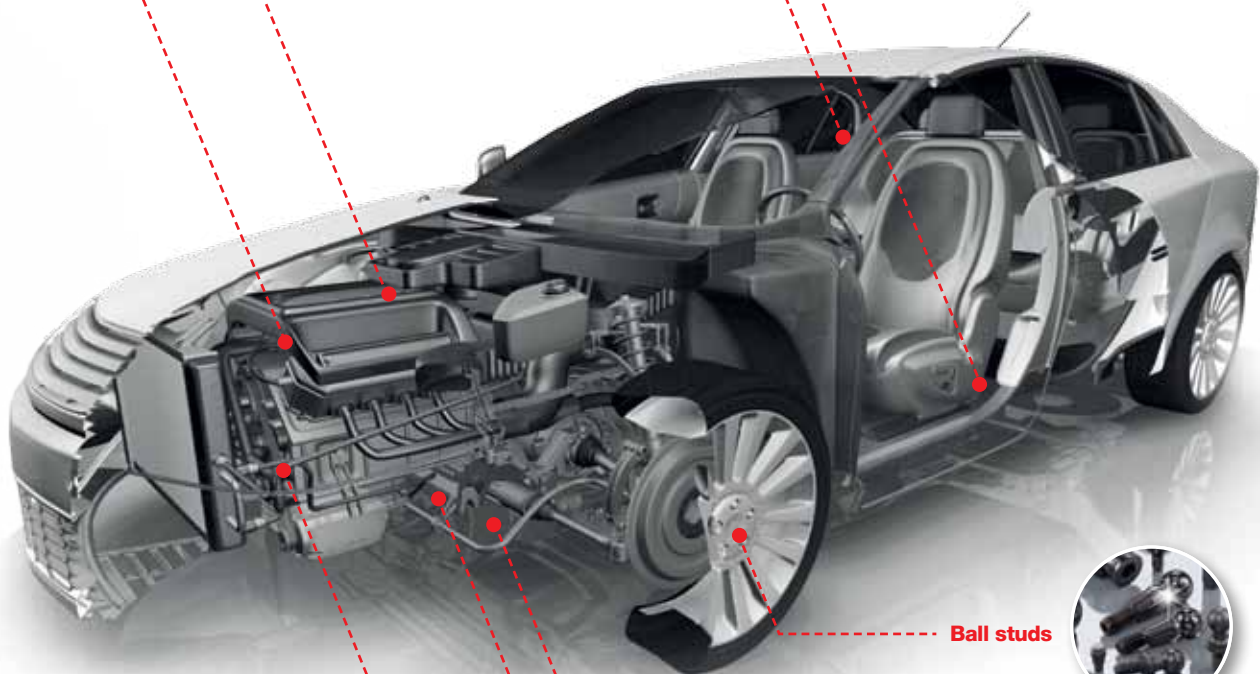

Ball studs

Injector needles / Valve pistons / Injector nozzles



Synchronizer rings



Tappets / Valves / Rocker arms



Oerlikon Balzers is a global specialist for surface treatments in the automotive industry. In addition to the innovative BALITHERM® heat-treatment approach, Oerlikon Balzers also offers high-performance PVD/PACVD coating solutions.

Our experts will be happy to advise you regarding your individual application requirements.

**Benefit from our efficient and environmentally friendly
BALITHERM service
Contact us today!**

Headquarters

Oerlikon Balzers Coating AG
Balzers Technology & Service Centre
Iramali 18
9496 Balzers
Liechtenstein
T +423 388 7500

China

Oerlikon Balzers Coating
(Suzhou) Co., Ltd.
No. 9 Changyang street
Suzhou Industry Park
Jiangsu Province
Suzhou 215024
China
T +86 512 67620369

Oerlikon Metco Surface
Technology (Shanghai) Co., Ltd.
B1 & B2, No. 539, Baian Road,
Anting
Jiading District
Shanghai 201814
China
T +86 21 67087000

Germany

Oerlikon Metaplas GmbH
Theodor-Heuss-Straße 63
38228 Salzgitter
Germany
T +49 5341 8587-0

Oerlikon Metaplas GmbH
Bernd-Beltrame-Straße 5
09399 Niederwürschnitz
Germany
T +49 37296 9324-0

Oerlikon Balzers Coating
Germany GmbH
Hohe-Flum-Straße 22
79650 Schopfheim
Germany
T +49 76 22 39 99-0

Japan

Oerlikon Nihon Balzers
Coating Co., Ltd.
Shizuoka PPD Factory
1110-10 Kamo
Shizuoka Pref.
Kikugawa-City 439-0031
Japan
T +81 537 35 8843

Korea

Oerlikon Balzers Coating
Korea Co., Ltd.
66, Gwahaksandan 1-ro
Gangseo-gu
Busan 46742
South Korea
T +82 51 974 9900

USA

Oerlikon Balzers Coating USA, Inc.
109 Parkway East
Pell City, AL 35125
United States
T +1 205 884 1210

You can find a full listing
of our locations at:

www.oerlikon.com/balzers

The future is along for the ride

BALITHERM IONIT & IONIT OX – The efficient
and environmentally friendly surface treatments
for the automotive industry

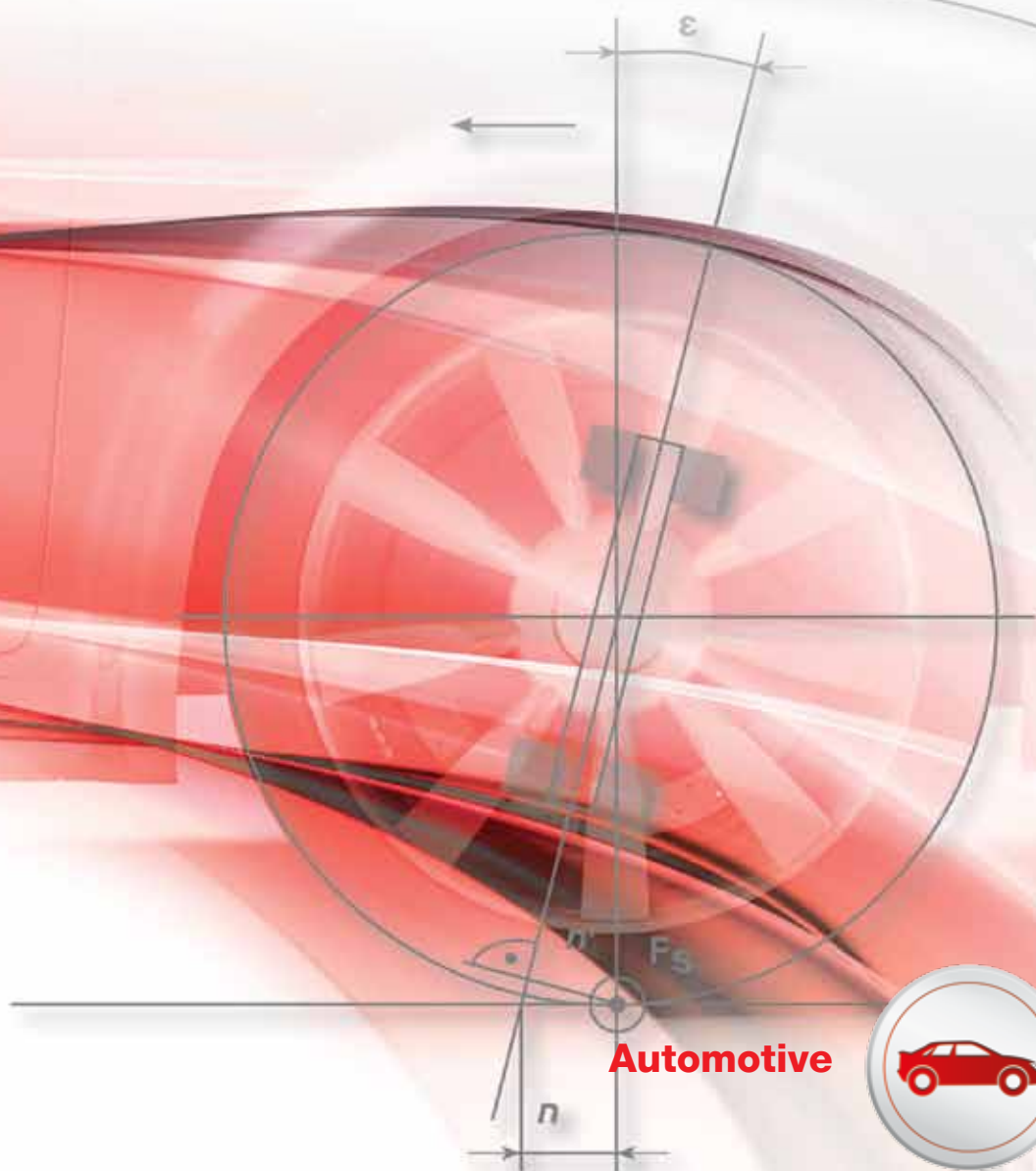

Get more power onto the road: with the surface hardening solution for suspension components

To remain competitive in the suspension technology field means you need components that deliver performance. Oerlikon Balzers has the ideal solution: The advanced heat treatment processes BALITHERM® IONIT & IONIT OX. They make ball studs, tie rods, brake discs and many other suspension components wear resistant and durable.

Moreover, with BALITHERM® IONIT & IONIT OX, no hazardous chemicals are used. That makes them the efficient and environmentally friendly alternative to common methods of treatment, such as hard chrome plating or salt bath nitriding. Take advantage of the many benefits offered by Oerlikon Balzers, a worldwide technological leader in the field of hard coating solutions.

Take advantage of numerous benefits

- Corrosion protection
- Low friction coefficient
- Material substitution: Cost-optimized material selection
- Higher energy efficiency
- Improved break-in properties
- Longer component service life
- Improved dimensional stability
- Reduced CO₂ emissions
- Environmentally friendly process
- Replacement of hard chrome plating and salt bath nitriding

The requirements for more efficient transmission components

Wear Mechanism	Required Properties
Adhesive wear	<ul style="list-style-type: none"> ■ Low friction coefficient ■ Low affinity between the materials (adhesive force, mutual solubility)
Abrasive wear	<ul style="list-style-type: none"> ■ High surface hardness ■ Low friction coefficient ■ Low roughness ■ High fracture toughness
Fatigue wear	<ul style="list-style-type: none"> ■ Residual compressive stresses ■ High elasticity
Erosion	<ul style="list-style-type: none"> ■ High surface hardness ■ High elasticity
Corrosion	<ul style="list-style-type: none"> ■ High chemical and thermal stability ■ Diffusion barrier

Application examples

- Gear-shift shafts
- Tie rods
- Brake discs and brake pistons
- Camshafts
- Ball studs
- Ball sleeves
- Attachment parts
- Clutch segments
- Disc carriers
- Synchronizer rings
- Pinion shafts

BALITHERM IONIT OX means: 8 fewer work steps – and up to 30% lower costs!

Imagine meeting the requirements for corrosion resistance, wear protection and strength while at the same time achieving cost-effectiveness in production:

The example of a gear-shift shaft that has been treated with BALITHERM® IONIT OX shows how this works.

The number of work steps can be reduced from ten to two thanks to surface treatment of the component.

Corrosion resistance: Corrosion free in individual cases after up to 700 hrs. using salt spray test

Wear protection: Formation of an oxide layer (1-2 µm), compound layer (10 + 10 µm)

Component strength under dynamic mechanical loading: Surface hardness of 650 + 100 HV 0.3



Manufacture component to final dimensions
BALITHERM® IONIT OX

30%
lower
costs

- Production with grinding requirements
- Cleaning
 - Covering
 - Case Hardening
 - Cleaning
 - Aligning
 - Pre-grinding
 - Partial chrome plating**
 - Annealing for H₂ degassing
 - Finish grinding

First-class coating properties

	BALITHERM® IONIT OX	BALITHERM® IONIT
Surface composition	$\epsilon + \gamma + \text{Fe}_3\text{O}_4$	$\epsilon + \gamma$
Compound layer thickness [µm]	10-28	6-15
NHD [mm] (nitriding hardness depth)	0.1-0.5	0.05-0.9
Oxide layer thickness [µm]	1-3	–
Hardness [HV]	300-900	300-1400
Max. application temp. [°C]	600	600
Friction coefficient μ (dry, against steel)	0.15	0.5

Support in every development phase: Rely on the competence of Oerlikon Balzers

With Oerlikon Balzers, you have a partner at your side that has many successful years of experience working with the automotive industry. Our development engineers and consultants assist you from the conceptual phase right on through to later serial production.

They offer advice in selecting the material, the correct design form and the subsequent processing. Moreover, you benefit from innovative, customized surface treatments, our worldwide service centres and much more.



Benefit from:

- Standardized and individualized coating solutions
- Global presence with over 100 Service Centres
- Know-how and logistics for contract treatment
- Consulting in applications and materials technology
- Individualized services: For example, automated and standardized fabrication processes, quality analysis, handling and cleaning, reconditioning as well as research and development

The decisive advantage for more efficiency: The service process

