

**oerlikon**  
balzers

# Strong and efficient on the road

BALINIT coatings for truck engines and  
gear components



**General Engineering**



# BALINIT coatings for truck engines and gear components

Truck engines are facing a significant demand for increased engine efficiency to meet national emission regulations. PVD and DLC coatings of engine and gear components can contribute lower fuel consumption by reducing friction and wear. BALINIT® DLC coated wrist pins have the potential to replace bronze bushings at increased engine pressures. Coated wrist pins and coated valve train tappets contributed

to a combined reduction of power consumed equalling of 1 kW in a test engine. BALINIT® CNI (CrN) coated valves and piston rings have superior wear resistance compared to hard chrome plating. BALINIT® C (WC/C) coating increases the load-bearing capacity and significantly reduces friction losses in rear axle gears.

## Your advantage with BALINIT-coated engine and gear components

- Higher engine pressures possible due to replacement of bronze connecting-rod bushes by coated wrist pins
- Increased engine efficiency due to friction-reducing engine components
- Less fuel consumption due to reduced friction in rear axle gears

## We recommend: BALINIT coatings for higher engine efficiency

	BALINIT® C	BALINIT® DLC	BALINIT® CNI
Coating material	WC/C	a-C:H	CrN
Microhardness (HV 0.5)	1,000	2,500	1,750
Typical thicknesses	2 – 4 µm	2 – 4 µm	4 – 50 µm
Coefficient of friction against steel (dry)	0.1 – 0.2	0.1 – 0.3	0.5
Colour	Black-grey	Black-grey	Grey

## Benefit from reduced power consumption with DLC-coated engine parts



**BALINIT® DLC coating on wrist pins reduces the power consumption of a truck engine by 600 W**

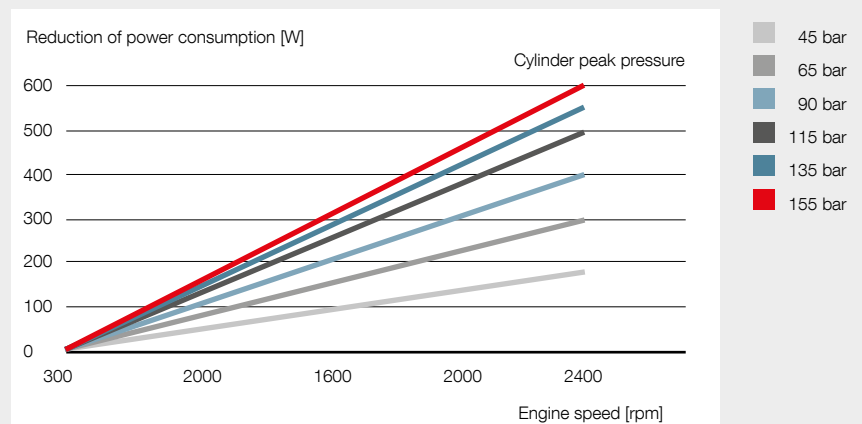

**BALINIT® DLC coating of tappets reduces the power consumption of a truck engine by 400 W**

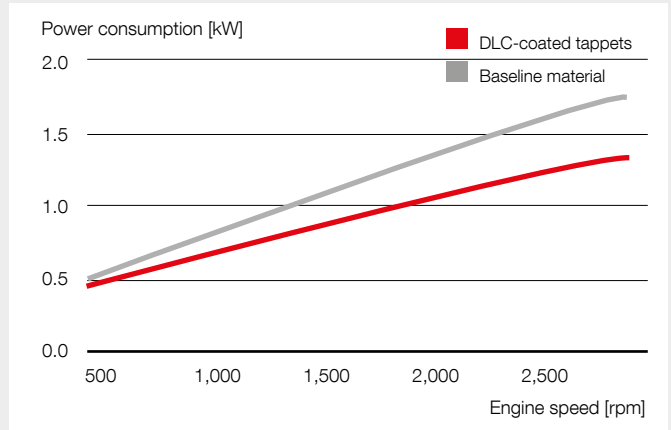
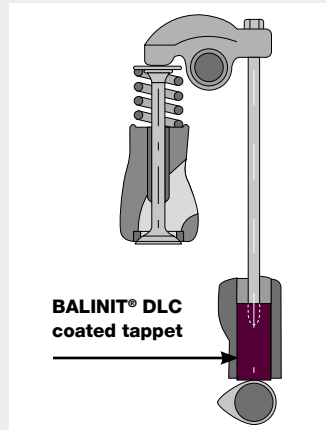

**BALINIT® C coating of rear axle gears reduces the power consumption of gear drive by 1.5 kW**

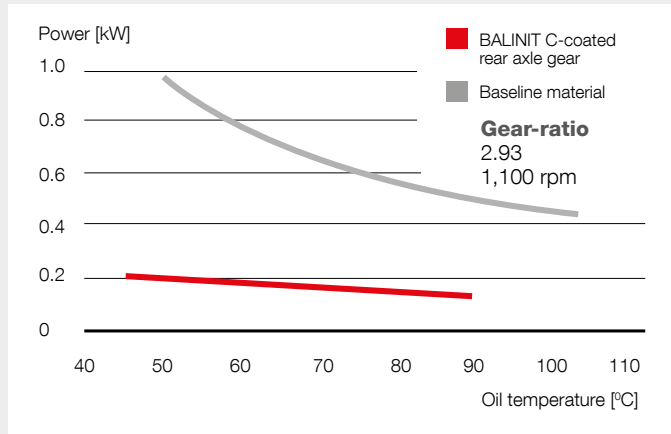

**BALINIT® CNI (sputtered CrN) coating is used for piston rings due to its superior hardness (1750 HV) compared to hard chrome plating (1000 HV)**

BALINIT® CNI significantly improves the wear resistance of the hard chromium base layer. The PVD coating is 40 µm thick.

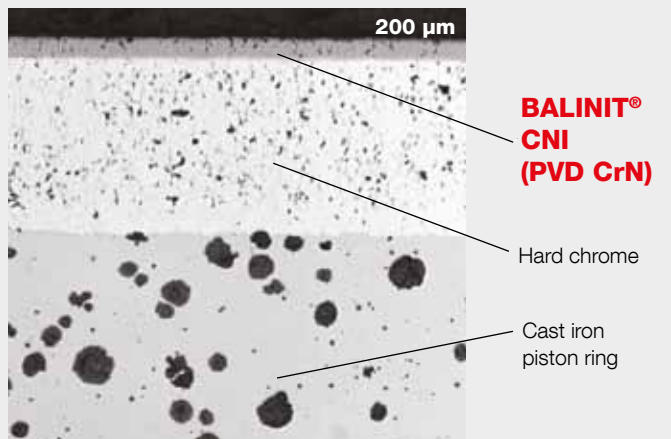

**BALINIT® CNI (sputtered CrN) coating reduces the friction and wear of valve tips and shafts and impedes the hydrocarbon build-up on the valve neck.**

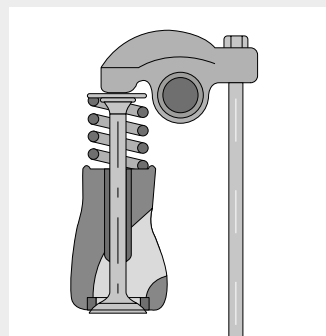

**There's much more to talk about – please get in touch to discuss how we can help you to improve your business.**

**Headquarters**

Oerlikon Balzers Coating AG  
Balzers Technology & Service Centre  
Iramali 18  
9496 Balzers  
Liechtenstein  
T +423 388 7500  
F +423 388 5419  
E [components.balzers@oerlikon.com](mailto:components.balzers@oerlikon.com)

Our worldwide coating centre  
network addresses are listed at:  
[www.oerlikon.com/balzers](http://www.oerlikon.com/balzers)

HQ196EN (1510)

**oerlikon**  
balzers