

Product Data Sheet

Metco 5MPE Series Powder Feeders

The Metco™ 5MPE series of powder feeders are designed to operate with manual and semi-automatic thermal spray systems. Two models are available. The 5MPE can be used for atmospheric plasma spray and combustion powder Thermospray™. The 5MPE-HP can be used for the HVOF spray process, as well as atmospheric plasma spray and combustion powder Thermospray.

The Metco 5MPE series powder feeders are based on proven fluidic powder feed technology for air plasma spray, combustion powder Thermospray and HVOF (high velocity oxy-fuel). Leveraging Oerlikon Metco technological know-how and manufacturing experience, the 5MPE is able to provide consistently reliable performance at low cost.

The 5MPE has been designed for use with manual and semi-automated spray systems, and is compatible with existing Metco semi-automatic controllers and spray guns.

Two 5MPE powder feeders can be used with spray controllers capable of controlling multiple feeders, which is useful for very long spray campaigns or applications using a bond coat followed by a top coat. For customers having a Metco 9MC plasma system and an occasional need for a second feeder, the 5MPE is a very economical choice.

The 5MPE-HP model is compatible with HVOF spray equipment, and equipped with specialized safety features for this process. Customers who run more than one thermal spray process, including HVOF, may choose use the 5MPE-HP for all of their spray needs.

The space-saving, tabletop design has a hopper that is simple to fill and clean out. Operation of the 5MPE is simple, using a precision rotameter to control carrier gas flow and easy to read and set pressure gages to control carrier gas flow and the rate of powder feed. Solid state electronics ensure dependable operation.



5MPE – Standard Configuration



5MPE – Configuration with optional PFRM Powder Feed Rate Meter and PFRMW Wind Cover



5MPE-HP – Standard Configuration (includes PFRM Powder Feed Rate Meter)

1 General Description

The powder material is gravity fed from the tapered hopper and is fluidized by the carrier gas at the base of the hopper. A vibrator assists gravity feeding of powders and helps in powder fluidization. Carrier gas enters the hopper base and passes the fluidization area through a pickup shaft. A controllable pressure differential between the hopper and the carrier gas stream moves the powder out of the hopper through to the spray gun. Increasing the pressure differential increases the powder feed rate.

A light on the front panel indicates that carrier gas is flowing and the unit is ready to feed. A second indicator light indicates when powder is feeding. Particle filters prevent the possibility of fine powder back flow into the supply lines.

A large, easy-to-read, precision flowmeter is mounted on the front panel.

The 5MPE model is equipped with a production-sized, 5.7 l (6.3 dry qt) hopper. The 5MPE-HP has a 3.2 l (3.5 dry qt) high-pressure hopper designed for the HVOF process. The

top of the hopper unclamps to fill the hopper. To remove remaining powder, the bottom of the hopper can be opened. This also facilitates cleaning of the hopper to prevent cross contamination of different spray materials.

Compact in design, a 5MPE powder feeder can be set on a table or countertop. The optional LCPT cart is available, with wheels and storage drawers.

The PFRM (Powder Feed Rate Meter) precisely monitors and controls the powder feed rate. This device is standard on the 5MPE-HP model, and can be purchased as an option for the 5MPE model. The optional PFRMW wind cover used in conjunction with the PFRM will provide the best feed rate stability, and should be used in shop environments with turbulent air conditions.

The Metco 5MPE series powder feeders are CE-conformant. They are built to the latest safety standards and are quipped with a global, switching power supply for 120/230 VAC, 50/60 Hz operation.

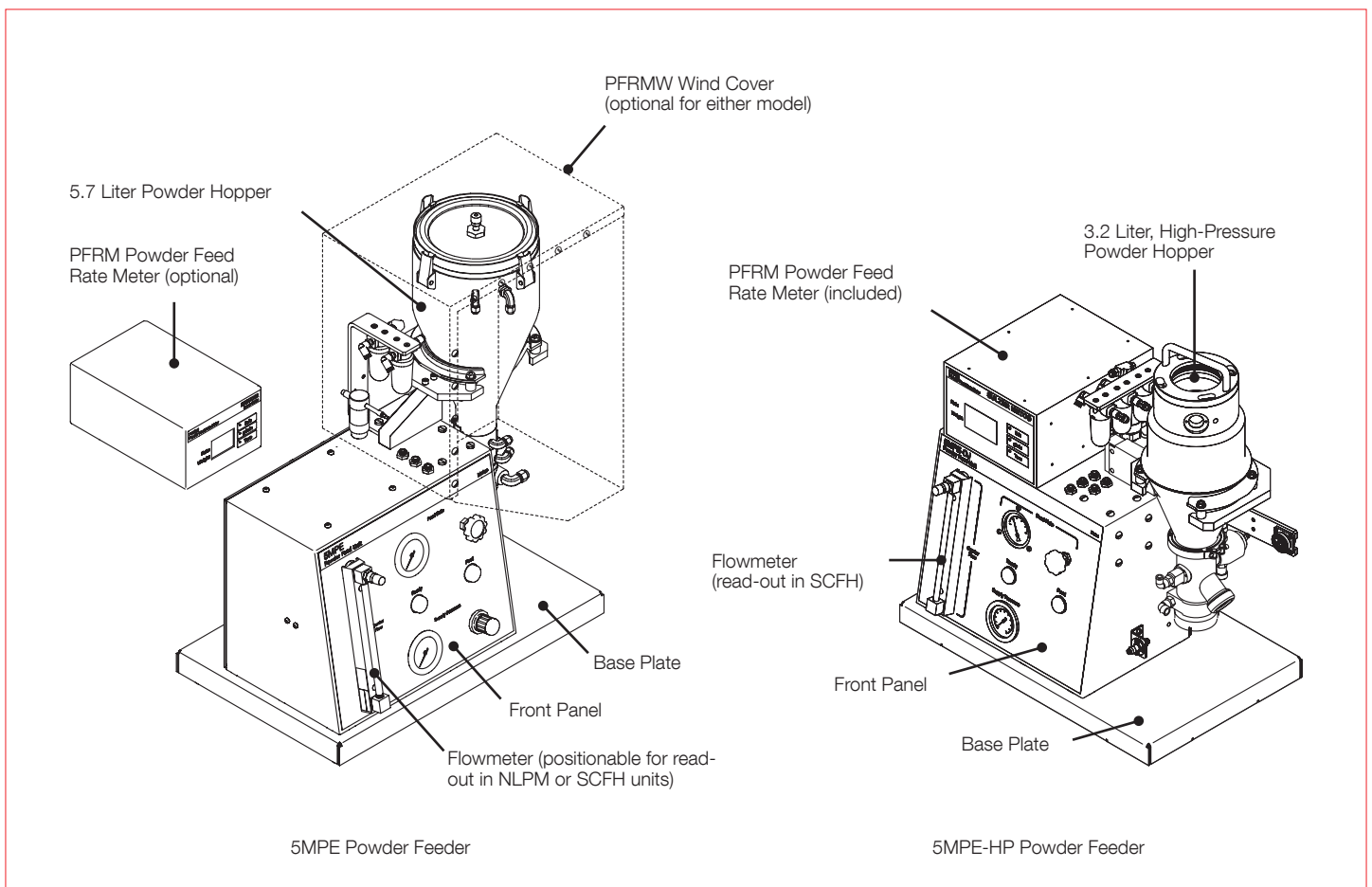

2 Features and Benefits

Effective

- Reliably feeds powder with high precision
- High-quality flowmeter precisely controls carrier gas.
- Solid state electronics improve reliability and precision.
- Compatible with Metco semi-automatic spray controllers and manual spray systems; for non-CE consoles, the 5MPA Adapter Assembly is required for compatibility with semi-automatic controllers.
- Global, switching power supply for use with 120 or 230 VAC, 50/60 Hz.
- Two units can be used for dual feed applications.

Economical

- Low cost of ownership.
- Low maintenance requirements, saves time and cost.

3 Accessories and Options

Oerlikon Metco offers options that allow configuration of the 5MPE series powder feeders with different controllers and for different production requirements. These include carrier gas supply hoses, powder feed hoses, O-rings, pickup shafts and interface modules. For a complete list of optional parts and spare parts, please refer to the parts lists section of the reference manual.

PFRM Feed Rate Meter (optional for 5MPE model, included with 5MPE-HP model) precisely measures, monitors and controls the powder feed rate, displaying units in g/min or lb/h. A tare function is also provided.

PFRMW Wind Cover is recommended for use with the PFRM for optimal feed rate stability.

5MPA Adapter Assembly is used to connect a 5MPE series feeder to a non-CE conformant Metco 9MC, 6C or DJC controller.

4 Technical Data

4.1 Dimensions

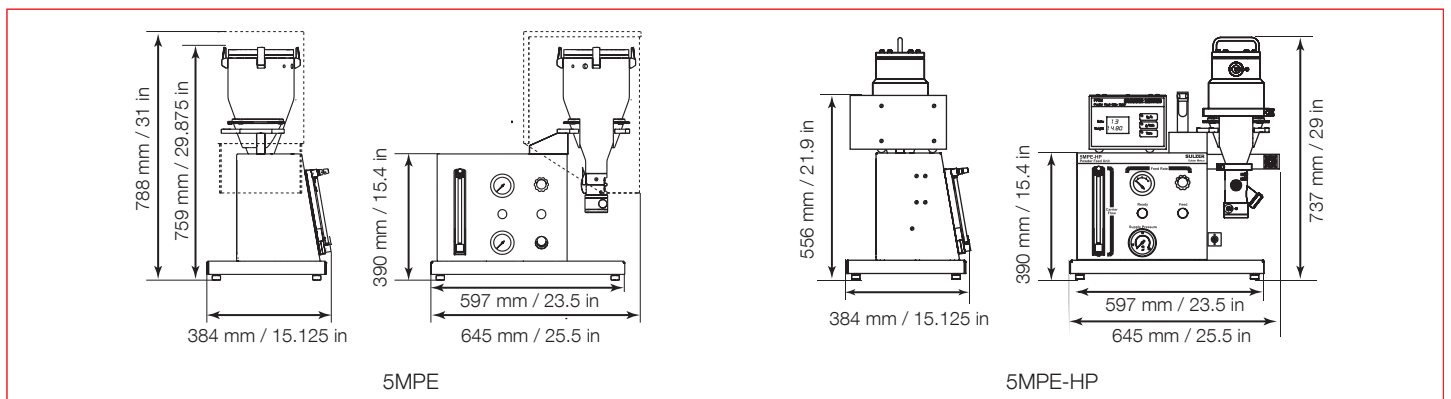

Effective

- Simple to operate, with easy powder cleanout and refill procedures.
- Large, easy-to-read, precision supply pressure gauge in both Metric and English units.
- Large, 5.7 l, production-sized hopper on 5MPE model for long spray campaigns. A smaller, 1.9 l hopper is optionally available.
- High-pressure, 3.2 l hopper on 5MPE-HP model for the HVOF spray process.
- Space-saving, tabletop design.

Economical

- Built to meet the latest safety standards.
- Fully CE conformant.

LCPT Cart supports the 5MPE powder feeder at a comfortable working height, has wheels for easy transport of the feeder and drawers to store spare parts and tools.

MPHE Gun Handle Assembly for stand-alone (no control console) operation of the 5MPE powder feeder. The MPHE can also be purchased for use with older model 6P-II-HE Thermospray guns not supplied with a MPHE handle. Includes powder feed on/off and integrated cable. CE conformant.

5MPE58365 Adapter Cable is used to connect a 6P-II, 6P-II-H (non CE) or DJ manual gun via the 6P590 control cable or 6P510/DJ125 gun handle assembly.

PKG58423 Remote Control Assembly is for stand-alone operation of the 5MPE series feeder. Provides powder feed and carrier gas on/off and E-stop capability.

4.2 Specifications

		5MPE	5MPE-HP
General Specifications			
Weight with hopper		30 kg 66 lb	34 kg 75 lb
Mounting		tabletop	tabletop
Power			
Voltage		120 to 230 VAC	120 to 230 VAC
Frequency		50 to 60 Hz	50 to 60 Hz
Power Consumption (max)	Feeder unit	75 W	75 W
	PFRM	(optional)	60 W
Precision			
Feed Rate		± 5 % of setting	± 5 % of setting
Operating Environment			
Temperature		10 to 40 °C 50 to 105 °F	10 to 40 °C 50 to 105 °F
Relative Humidity	Non-condensing	< 75 %	< 75 %
Carrier Gas Requirements			
Nitrogen – N ₂	Pressure	2.7 bar 40 psi	11 bar 160 psi
	Flow	2 to 11 NLPM 3 to 25 SCFH	1.9 to 22.4 NLPM 4.1 to 47.4 SCFH
Argon – Ar	Pressure	4 bar 60 psi	
	Flow	2 to 11 NLPM 3 to 25 SCFH	
Vibrator Air Requirements			
Pressure		1.4 to 4.1 bar 20 to 60 psi	1.4 to 4.1 bar 20 to 60 psi
Flow		28 to 113 l/min 1 to 4 ft ³ /min	28 to 113 l/min 1 to 4 ft ³ /min
Quality		clean, dry and oil-free	clean, dry and oil-free
Compatibility			
Controllers		6C*, 6CE, 9MC*, 9MCE and manual combustion powder Therospray systems	UniCoatPro-LF, DJC*, DJCE and manual HVOF systems

* 5MPA Adapter Assembly is required